



MANUAL DE OPERACIÓN

**CALDERAS PIROTUBULARES
STEAM**



Manufactured in the USA
to the ASME boiler and
pressure vessel code



SCOTCH MARINE FIRETUBE STEAM BOILER MANUAL

2-Pass & 3-Pass Dryback
High & Low Pressures
40 - 2500 BoHP
Gas / Oil / Gas & Oil

Zona Industrial Municipal
Norte, Av. Este - Oeste,
Centro Funval, Local N° 8,
Valencia, Estado
Carabobo, Venezuela.

Teléfonos:
(+58241) 832.62.75 -
832.12.37 - 832.96.40

Email:
info@vaporotec-corp.com
- mercadeo@vpica.com

TABLE OF CONTENTS

Table of Contents	2-4
Related Documents	5
Acronyms, Definitions, Standards & Sources	6
Introduction & Safety	7
Approvals & Recordkeeping	8

No.	Section	Figures	page
1	BOILER SIGNAGE	Figures 1-0...1-11	9-13
2	BOILER STATISTICS		
	Model numbering	Figure 2	14
3	COMPONENT IDENTIFICATION		
3.0	Steam boiler	Figures 3	15
3.1	Cross sections	Figures 5	15
3.2	Pass configuration	Figures 5, 6	16
3.3	Water columns	Figures 7, 8	18
3.4	Typical basic temp & pressure controls	Figures 9, 10	19
3.5	Water level controls	Figures 11, 12	20
3.6	Typical temp & pressure controls	Figure 13	21
3.7	Smoke Box's	Figures 14	22
3.8	Cleanout Plug	Figures 15, 16	23
3.9	Burner mounting	Figures 17, 18, 19	24
3.10	Burner mount packing	Figure 20	25
3.11	Feedwater piping	Figures 21, 22	26
3.12	Hand holes and Manway	Figures 23, 24, 25	27
3.13	Misc. images	Figures 26 – 30	28
3.14	Safety valves	Figures 31, 32	29
3.15	Blowdown valves	Figures 33, 34, 35	30
3.16	Surface blowdown systems	Figures 36, 37	31
3.17	Misc. images	Figures 38 – 42	32
3.18	Example fuel train schematics	Figure 43	33
4	SPECIFICATIONS		34
4.1	Steam boilers		36
5	BOILER INSTALLATION		
5.1	Receiving the boiler		38
5.2	Unloading the boiler-burner unit		38
5.3	Boiler unloading instructions		39
5.4	The boiler room		40
5.5	Setting the boiler		40
5.6	Extended storage procedure for boilers not yet installed		41
5.7	Installation of loose shipped items		42

No.	Section	page
5.8	Electrical installation	43
5.9	Miscellaneous installation guidelines	44
5.10	Boiler stack connection	45
5.11	Vent selection	46
5.12	Flue gas recirculation	46
6	PLUMBING YOUR BOILER	
6.1	Fuel supply & connections	47
6.2	Boiler connections, general	47
6.3	Water connections	47
6.4	Steam boiler feedwater connections	48
6.5	High pressure steam connections	48
6.6	Two or more high pressure boiler steam connections	48
6.7	Drains	48
6.8	Blowdown piping	48
6.9	Supplied blowdown valves	48
6.10	Blowdown connections	49
6.11	Safety valves	49
6.12	Safety & Safety relief valve discharge piping	49
7	BOILER STATUP	50
7.1	Operating data	50
7.2	Start-up Guidelines	50
7.3	Tools & gages	51
7.4	Fuel guidelines	51
7.5	Cleaning and filling a new boiler	51
7.6	Firing a new boiler	51
7.7	Boil-out Procedure	52
7.8	Start-up of Steam boilers	54
8	BOILER OPERATION	
8.1	Safety valves	55
8.2	Gages	57
8.3	Pressure controls	58
8.4	Temperature controls	59
8.5	Maintenance on pressure and temperature limiting controls	59
8.6	Example of set points adjustment procedure	60
8.7	Water level controls	62
8.8	Water level operations	
8.8.1	Gauge glass	64
8.8.2	Try-cocks	65
8.8.3	Steam boiler feedwater	65
8.8.4	Maintaining proper water level	65
8.8.5	High or low water level	66
8.8.6	High water level	66

No.	Section	page
8.8.7	Abnormal water losses	66
8.8.8	In case of low water	66
8.8.9	Water carryover	66
8.9	Water treatment	67
8.9.1	Heating boilers	67
8.9.2	Process steam boilers	67
8.9.3	Water treatment guidelines	68
8.10	Boiler Blowdown	
8.10.1	Boiler blowdown calculations	69
8.10.2	Blowdown procedures	70
8.10.3	Process boilers	70
8.10.4	Heating boilers	70
8.10.5	Bottom blowdown valve operation	70
8.11	Access openings and burner mount	71
8.11.1	Hand holes and Manway	71
8.11.2	Smokebox doors	71
8.11.3	Cleanout plug	71
8.11.4	Burner mount	71
8.11.5	Refractory	71
9	MAINTINANCE	72
9.1	Spare parts	72
9.2	Maintenance schedule	72
9.2.1	Daily procedures	73
9.2.2	Weekly procedures	74
9.2.3	Monthly procedures	75
9.2.4	Semi-Annual procedures	76
9.2.5	Annual procedures	77
9.3	Detailed empty inspection	79
9.4	Limit control tests	81
9.4.1	High limit steam pressure control	81
9.4.2	High & Low gas pressure switch limit test & adjustment	81
9.4.3	Electrical limit controls	82
9.4.4	Oil pressure supervisory switch	82
10	TROUBLESHOOTING	83
11	OUT OF SERVICE OPERATIONS	
11.1	Shutdown	84
11.2	Boiler taken out of service	84
11.3	Boiler laid up dry	84
11.4	Boiler laid up wet	85
11.5	Re-commissioning	85



Thank you for purchasing a Superior Boiler Works Inc. (SBW) product. This manual is for the **Dryback Steam** line of boilers. **READ AND SAVE THESE INSTRUCTIONS FOR REFERENCE.** These manual and associated documents are to be kept with the boiler and in legible condition for the life of the boiler.

This manual will refer to the burner’s manual when appropriate. A double asterisk (**) is used to indicate that your boiler manual should also be checked for information on the topic being covered unless otherwise noted. In addition to the boiler and burner working together, there are controls, switches, valves, and other components on your boiler assembled specific to each end user. A list of exact components, and information about them, are appended to this manual. All of these documents and devices work together to safely operate your boiler.

DOCUMENT UNIQUE TO YOUR BOILER

There are many Superior Boiler Works Inc. (SBW) Documents created unique to each boiler. These documents are appended to this manual either directly after this structured manual.

Document	# of pages	Page #/Location
• Cover page with your information	1	Zero/First
• Specification sheets	4	Appendix 1
• Ratings and dimension drawing,	1	Appendix 2
• Recommended spare parts,	1 to 3	Appendix 3
• List of component manuals	1 to 4	Appendix 4
• ASME data reports	1 to 12	Appendix 6
• Fire test report (if tested)	0 to 4	Appendix 7
• MSDS Information (If supplied)	0 to 9	Appendix 8
• Miscellaneous unique paperwork for this boiler	Any	Appendix 9
• Wiring drawing(s)	can be large format	Last

MANUALS THAT COME WITH THIS MANUAL:

This manual is intended to be used in conjunction with other documents.

- Burner manual, and manuals that comes with the burner. Appendix 10
- Manuals for every major component supplied with the boiler. Appendix 11

NOTICE!

Warranty validation/Start-up report information sheet must be filled out and return to SBW within three weeks of when the burner is first turned on and within two months of shipment of boiler to maintain your warranty. Also note that boil-out procedures, a slow initial warm up, and proper water treatment are required to maintain your warranty.

Acronyms, Definitions, Standards, & Sources

SBW: Superior Boiler Works Inc.

ASME: American Society of Mechanical Engineers

ASME CSD-1: Controls and Safety Devices for Automatically Fired Boilers

ASME B31: ASME code for pressure piping

BPVC: ASME boiler and pressure vessel code.

Section I: Portion of BPVC that applies Steam boilers operating over 15 PSIG

Section IV: Portion of BPVC that applies Steam boilers not exceeding 15 PSIG and water boilers not exceeding 160 PSIG or 250°F

Low pressure: Pressures not exceeding 15 PSIG

Power boiler: Section I steam boiler

Heating boiler: Low pressure steam or water boiler.

Process boiler: Power boiler that required a high percentage of makeup water.

Water boiler: Boiler that supplies hot water

LWCO: Low-water cutoff, or Low-water fuel cutoffs

Aux LWCO: Auxiliary Low water cutoff

LWCO mark: Vertical position on boiler where the primary LWCO operates

ANSI: American National Standards Institute

150# class: ANSI standard of flanged piping connections,

300# class: ANSI standard of flanged piping connections,

NPS: Nominal pipe size

NPT: National pipe thread (tapered)

MAWP: Maximum allowable working pressure

TOT: Top of tubes; the highest point in the boiler where flue gas passes through tubes.

Set point: A specific value of pressure or temperature used in a control where it will switch on or off.

Aquastat: Water temperature control device

BoHP: Boiler horse power: The evaporation of 34.5 lbs of water/hr. from a temperature of 212°F into dry saturated steam at same temperature. Equivalent to 33,475 Btu/Hr.

PSI: Pounds per square inch

PSIG: PSI gage reading.

In. WC: Inches of water column. Units of pressure where one (1) PSI = 2.8 In. WC (28" WC)

FGR: Flue gas recirculation or the recirculation of the flue gas with combustion air.

NFPA: National Fire Protection Agency

NFPA 31: Installation of Oil Burning Equipment

NFPA 54: National Fuel Gas Code

NFPA 70: National Electric Code, AKA: NEC

NFPA 85: Boiler and Combustion System Hazards Code

IFGC: International Fuel Gas Code

R&D drawing: Ratings and Dimensions drawings. AKA: General Arrangement.

Introduction to safety

WARNING

The improper installation, adjustment, service, maintenance, or operation of this equipment can result in fire, explosion, series injury, or death.

Refer to this manual and the burners' manual. For assistance or additional information consult a qualified installer, service agency, or fuel supplier as appropriate.

DO NOT STORE OR USE GASOLINE OR ANY OTHER FLAMMABLE LIQUIDS IN THE VICINITY OF THIS OR ANY OTHER APPLIANCE.
DO NOT USE GASOLINE, CRANKCASE DRAININGS, OR ANY OIL CONTAINING GASOLINE.
NEVER BURN GARBAGE OR PAPER IN THE UNIT, AND NEVER LEAVE COMBUSTABLE MATERIAL AROUND IT.

All Personnel involved with the startup, maintenance, or adjustment of this boiler must read and understand the entire contents of this manual prior to any startup or adjustment being made to the boiler and related components. Installation and service must be performed by a qualified installer, service agency or the fuel supplier.

Safe and reliable operation is dependent to a large extent upon the skill and attentiveness of the operator and the maintenance personnel. Operating skill implies the following:

- knowledge of fundamentals
- familiarity with equipment
- suitable background of training and experience

Full and effective use should be made of manufacturer's instruction books on operation and maintenance. Of special importance are written procedures prepared expressly for each installation by the manufacturers' service engineers and qualified personnel from the operating organization before and during the commissioning period. These procedures are based on actual experience and often include invaluable information on what the equipment is expected to do. Limitations critical to safe and reliable operations are also given. Control systems vary in complexity from computer control to manual operation. Regardless of the type of system used, the operators should be thoroughly trained so that they can maintain safe and continuous operation during changeover from automatic to manual control as well as to continue operation by manual control if the automatic systems are out of service. The operator should have instrumentation at the point of manual operation to permit him to be aware of operating conditions at all times. Regularly scheduled auto-manual changeover, manual operation, and emergency drills to prevent loss of these skills are recommended.

What to do if you smell gas:

- Do not try to light any appliance
- Do not touch any electrical switch
- Do not use any phone in your building
- Immediately call your gas supplier from a neighbors phone
- Follow the gas supplier's instructions
- If you cannot reach your gas supplier, call the fire department.

This is used to point out warranty issues.

NOTICE!

Approvals & Recordkeeping

All SBW boilers are designed, manufactured, and stamped to the ASME BPVC. Refer to the signage information section to determine the approvals that have been applied to your boiler.

THE INSTALLATION OF THIS BOILER SHALL BE IN ACCORDANCE WITH THE REGULATIONS OF AUTHORITIES HAVING JURISDICTION.

BOILERS SHALL BE OPERATED BY QUALIFIED PERSONNEL. BOILERS SHALL BE INSTALLED AND SERVICED BY QUALIFIED PERSONNEL ONLY.

Boilers intended for Canadian markets, refer to the following regulations as applicable:

The equipment shall be installed in accordance with the current Installation Code for Gas Burning Appliances and Equipment and applicable Provincial Regulations for the class, which should be carefully followed in all cases. Authorities having jurisdiction should be consulted before installations are made. The installation of the unit shall be in accordance with the regulations of the authorities having jurisdiction

Boilers intended for American markets, refer to the following regulations as applicable:

NFPA31: Installation of Oil-Burning Equipment
NFPA54: National Fuel Gas Code
NFPA85: Boiler and Combustion Systems Hazards Code
NFPA70: National Electrical Code
IFGC: International Fuel Gas Code

All drawings, wiring diagrams, schematic arrangements, manufacturers' descriptive literature, and spare parts lists, and written operating instruction should be kept permanently in the boiler room or other suitable location so it will be available to those who operate and maintain the boiler. Where space permits, drawing and diagrams should be frame or sealed in plastic and hung adjacent to the related equipment. Other materials should be assembled and enclosed in a suitable binder. When change or additions are made, the data and drawings should be revised accordingly.

READ AND SAVE THESE INSTRUCTIONS FOR REFERENCE.

Some states and municipalities require licensing or certification of personnel who operate or maintain heating equipment. Also, some authorities require posting of inspection certificates in the boiler room. The supervisor in charge of a given installation should make sure such requirements are met.

1 BOILER SIGNAGE

SBW boiler signage map: **Figure 1-0**

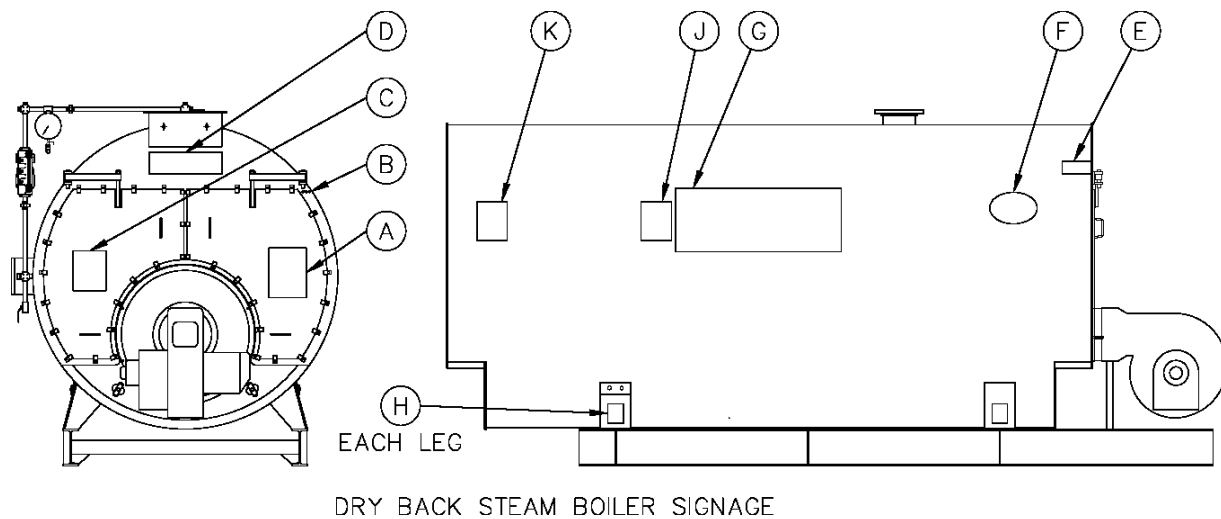

DRY BACK STEAM BOILER SIGNAGE

NAT'L BOARD NO.

MODEL NO.

SERIAL NO.

HEATING SURFACE SQ. FT.

DESIGN PRESS. P.S.I.

STEAM CAPACITY LBS./HR. YEAR BUILT

MIN. VALVE CAPACITY LBS./HR.

INSTALLATION: The boiler assemblies are intended for installation in accordance with the appropriate standards of the NATIONAL FIRE PROTECTION ASSOC.

For boilers operating at not more than 50 psi-18 in. at top, sides and rear, 48 in. from front and 18 in. from flue pipe.

For boilers operating at more than 50 psi-48 in. at top, 36 in. at sides and rear, 96 in. from front, and 36 in. from flue pipe.

For installation on noncombustible flooring.

3524 E. Fourth Ave. Hutchinson, KS 67501
 (620) 662-6693, Fax (620) 662-7586
 E-mail sbw@superiorboiler.com

Location A.

ASME steam boiler rating plate:
Figure 1-1

Refer to the SBW model numbering system for details

ASME "S" stamp signifies that the boiler is approved by AMSE to Section I of the BPVC

SV capacity. This is a collective value of all of your SV valves. Specific SV capacity can be found on the ASME forms.

The serial No. or National board No. are useful when contacting SBW for spare parts or support.

Location B. Punch marks: Figure 1-2

Three (3) punch marks are placed on the front of your boiler to locate where the top of the tubes are without opening the smoke box doors.

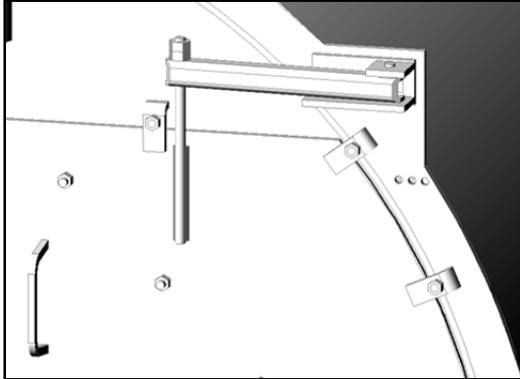

Location C. Warning plate: Figure 1-3

Every boiler includes this warning mounted on the front doors of the boiler close to eye level.



Location D. Logo plate: Figure 1-4

Mounted between the front doors and stack connector when space permits.



Location E. LWCO mark: Figure 1-9

Used to determine the correct elevation of the LWCO switch. Line this up with the primary level mark on the LWCO.

**Location F. ASME Drum stamping: Figure 1-10**

The ASME "S" Stamp is applied directly to the boiler's drum when ASME approval is given. This is also a good place to use a thermometer for shell temperature. Typically located on the upper half of the right side of the boiler about two feet from the front.

**Location G. Logo sticker: See figure 1-8**

Located on the middle side of the boiler.

Location H. Load Bearing Point sticker: Figure 1-11

Besides the lifting lugs, this shows the only locations the boiler should be lifted from.



Location J. Handling options sticker: Figure 1-7

This is to make clear how the boiler can be handled.

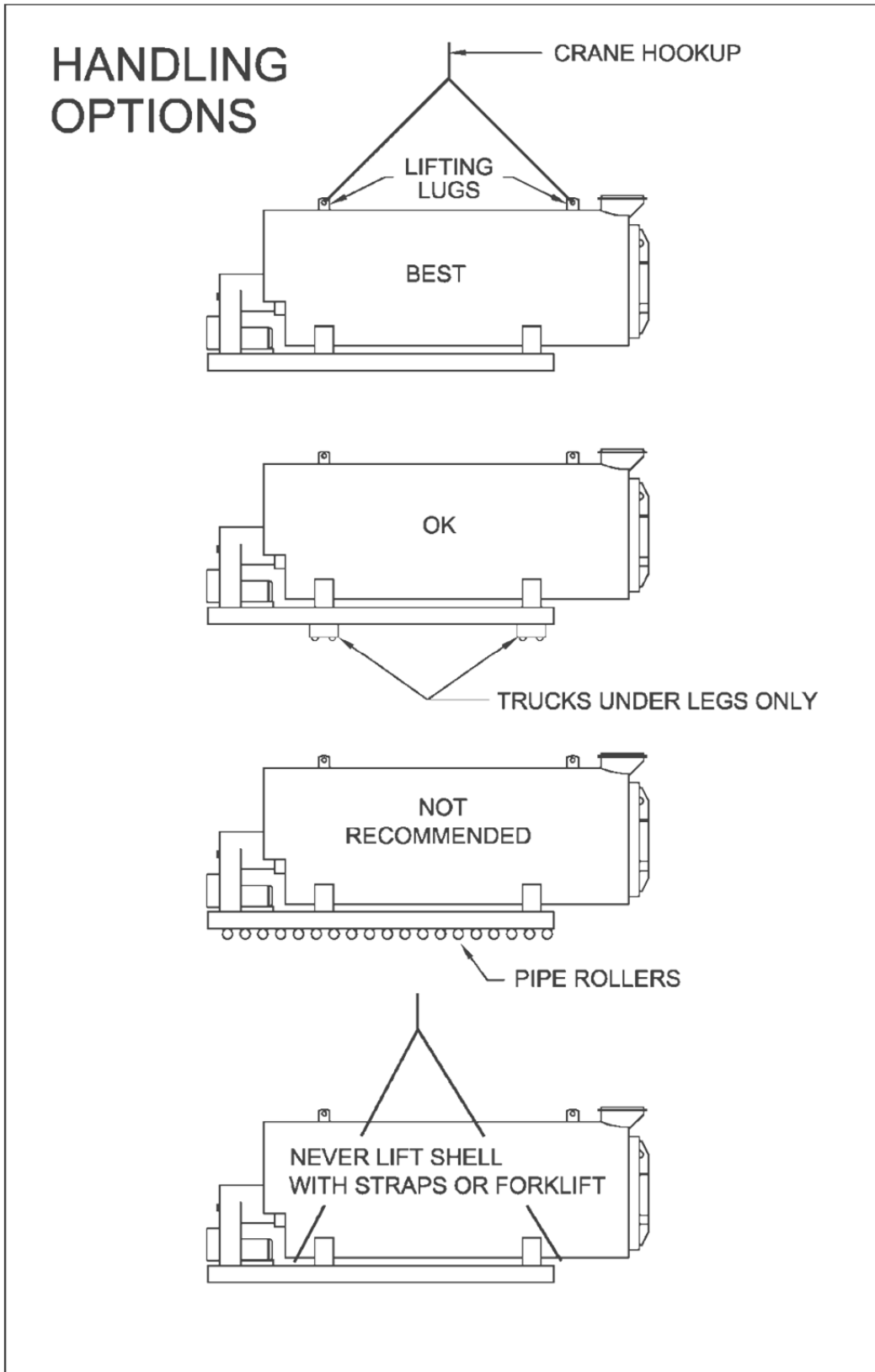

Location K. Bridge Support sticker: Figure 1-8
This is to make clear how the boiler can be handled.

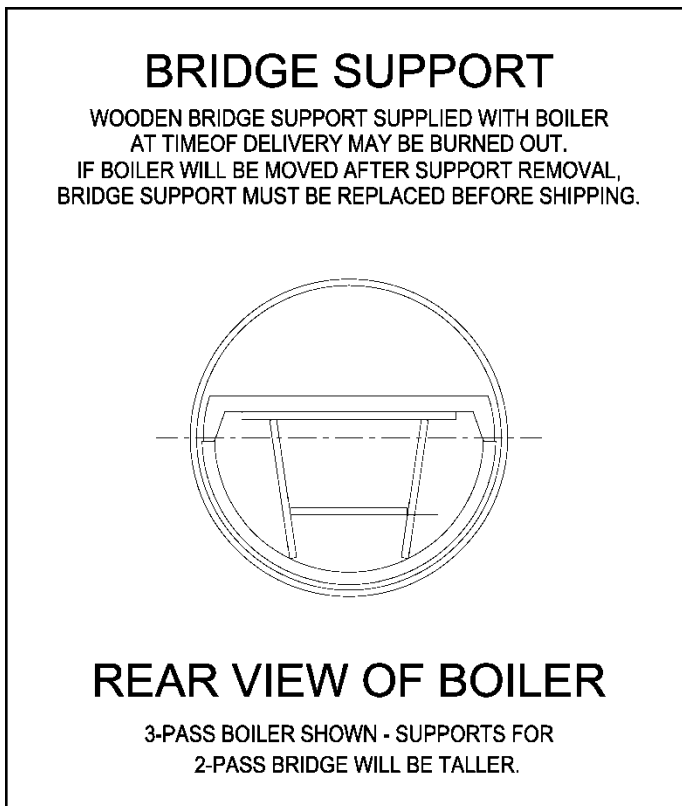

2 BOILER STATISTICS Model numbering: Figure 2

SUPERIOR BOILER MODEL NUMBERS

7 - 5 - 1024 - S150 - PF - G

Model

- AR Arrowhead (Modified Firebox)
- 2 Pawnee (2 Pass Dryback)
- 3 Osage (Standard Firebox)
- 4 Mohawk (3 Pass Dryback)
- 5 Aztec (2 Pass Dryback)
- 6 Seminole (3 Pass Wetback)
- X6 Super Seminole (3 Pass Wetback w/XID)
- 7 Mohican (4 Pass Wetback)
- 8 Apache (2 Pass Dryback)
- 13 Seneca (3 Pass Dryback)

Fireside Heating

Surface per H.P.

Total Fireside

Heating Surface

Design Pressure

S15	Steam 15#	W30	Water 30#
S150	Steam 150#	W60	Water 60#
S200	Steam 200#	W100	Water 100#
S250	Steam 250#	W125	Water 125#
S300	Steam 300#	W160	Water 160#

Burner

- PF Power Flame
- RL Riello
- STJ S. T. Johnson
- WB Webster Engineering
- WP Weishaupt
- IC Industrial Combustion
- M Less Burner
- Initials of Manufacturer

Fuels

- G Natural Gas
- LPG Liquified Petroleum Gas
- DG Digester Gas
- P2 #2 Oil Pressure Atomizing
- A2 #2 Oil Air Atomizing
- A5 #5 Oil Air Atomizing
- A6 #6 Oil Air Atomizing

3.0 COMPONENT IDENTIFICATION

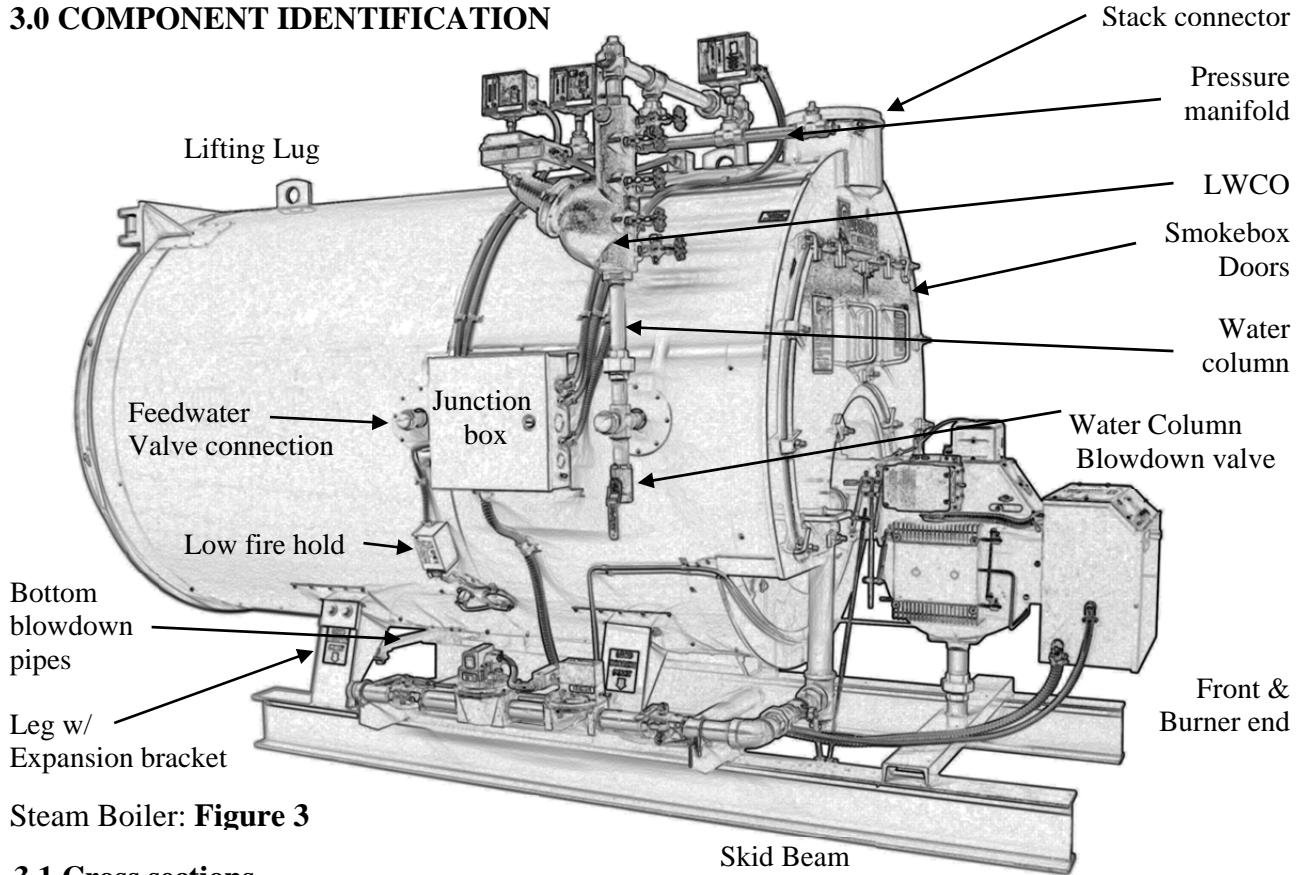

Steam Boiler: **Figure 3**

3.1 Cross sections

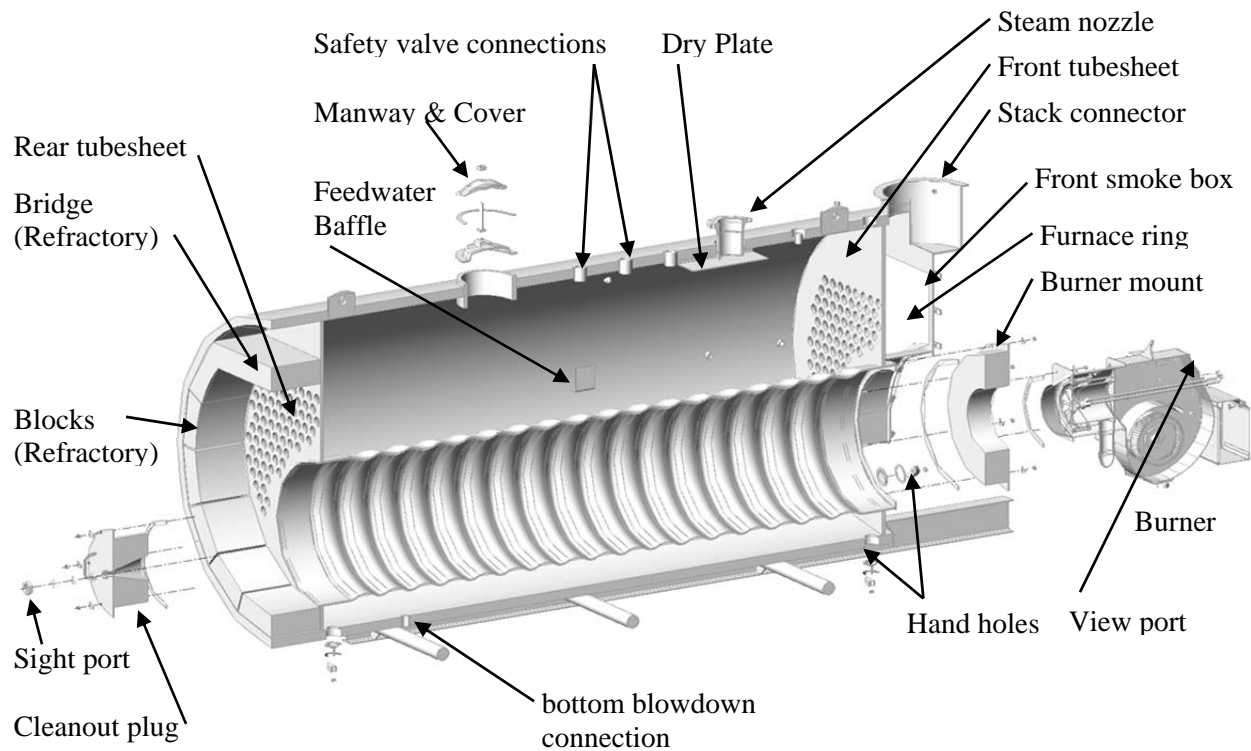

Steam boiler cross section (rear lid not shown): **Figure 4**

3.2 Pass configuration

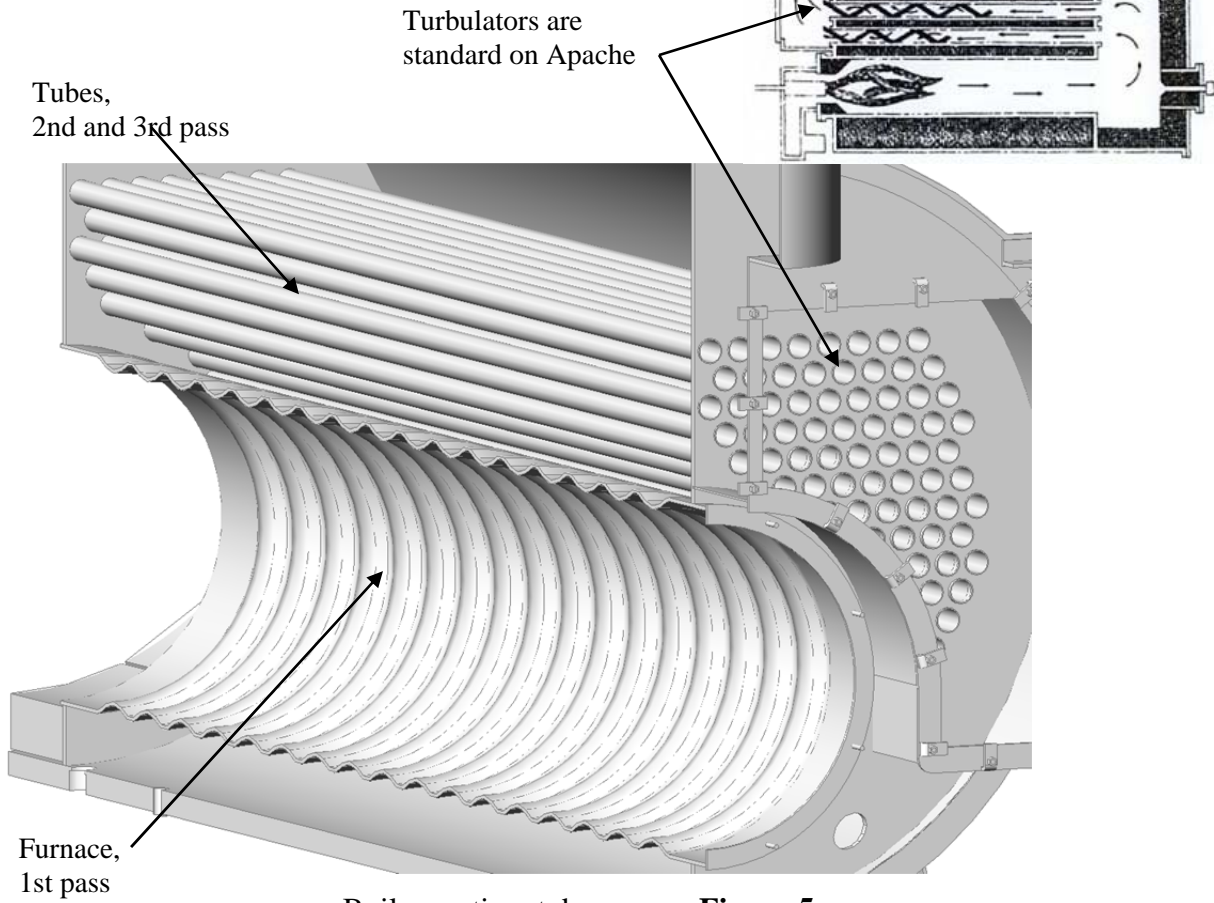

Boiler section, tube passes: **Figure 5**

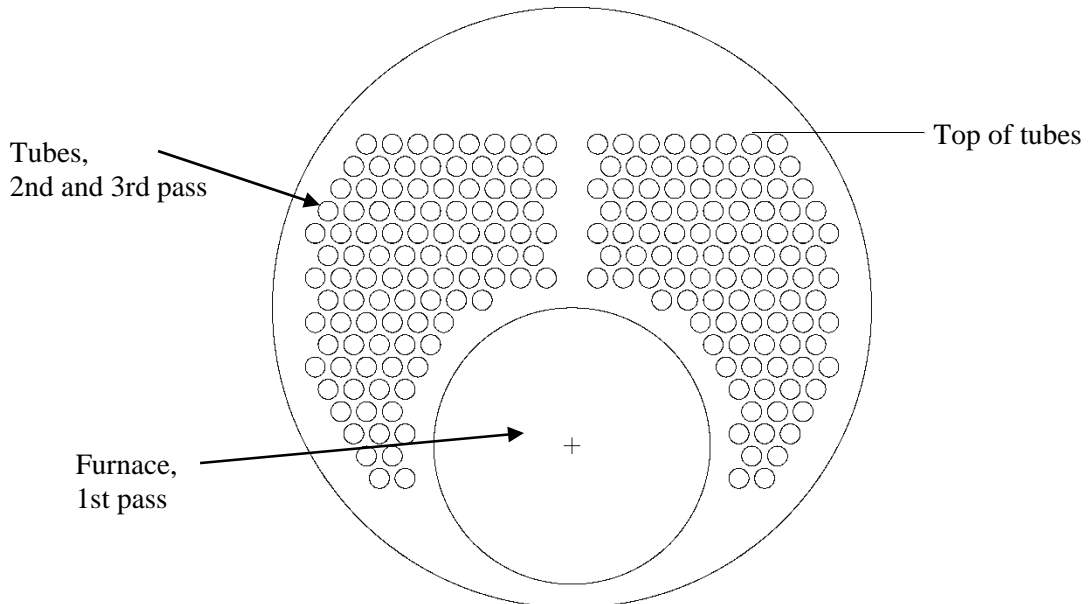

Example tube sheet: **Figure 6**

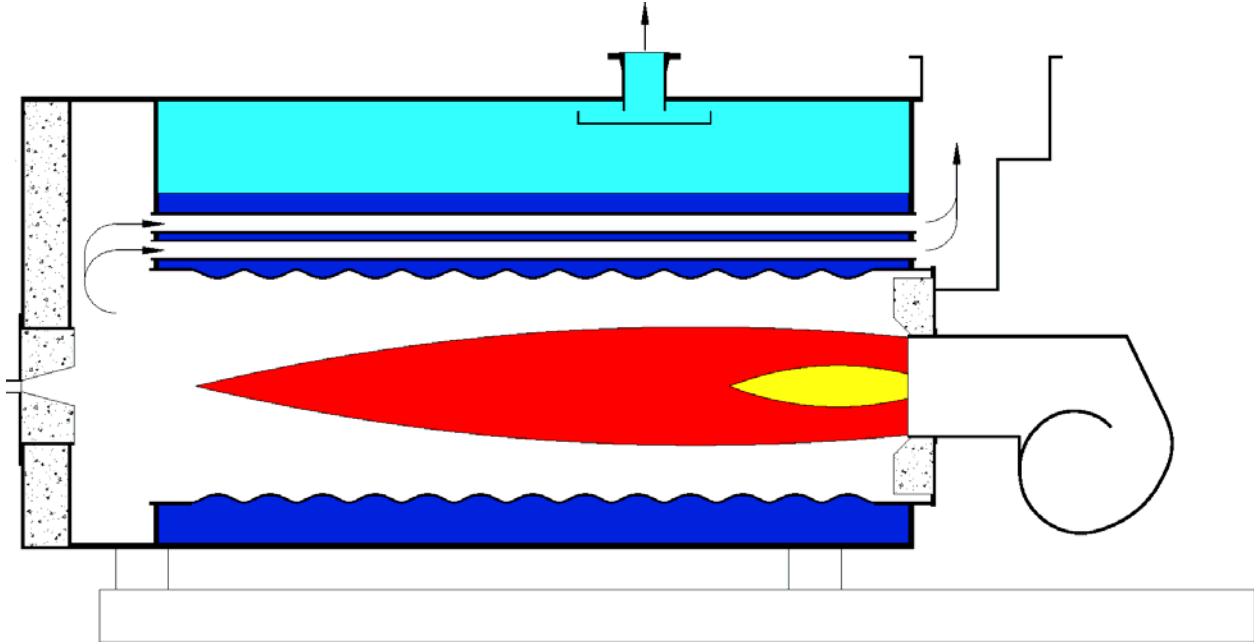

Graphic Depiction of 2-Pass Dryback Steam Pass Configuration

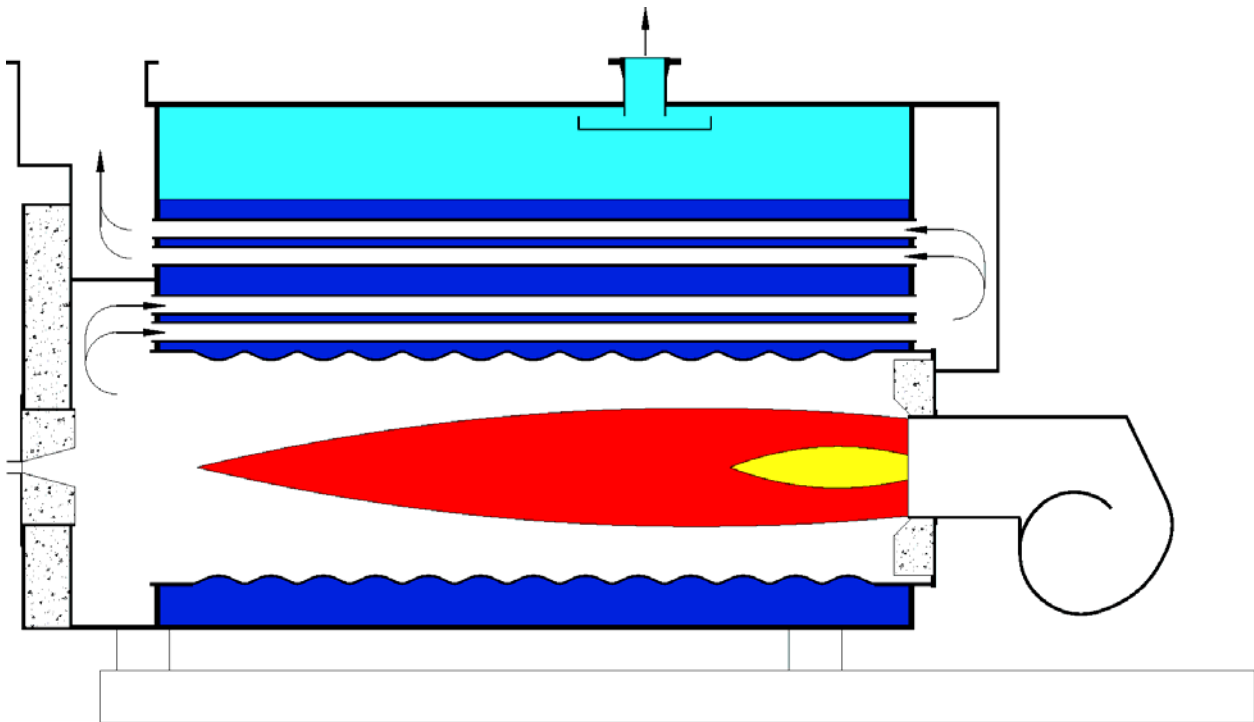

Graphic Depiction of 3-Pass Dryback Steam Pass Configuration

3.3 Water columns, Steam boilers

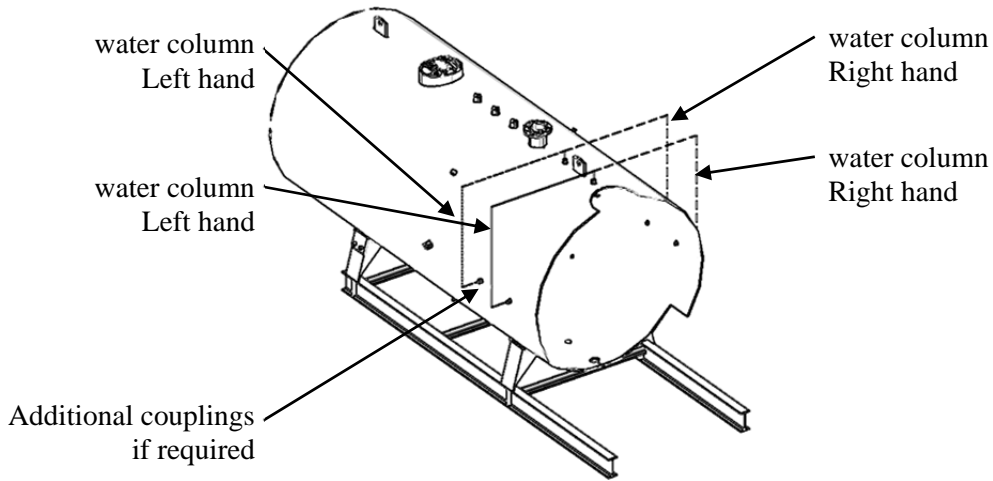

Water column options, **Figure 7**

One primary, and one auxiliary shown, more water columns are possible. Right, left, or both may be used depending on your configuration

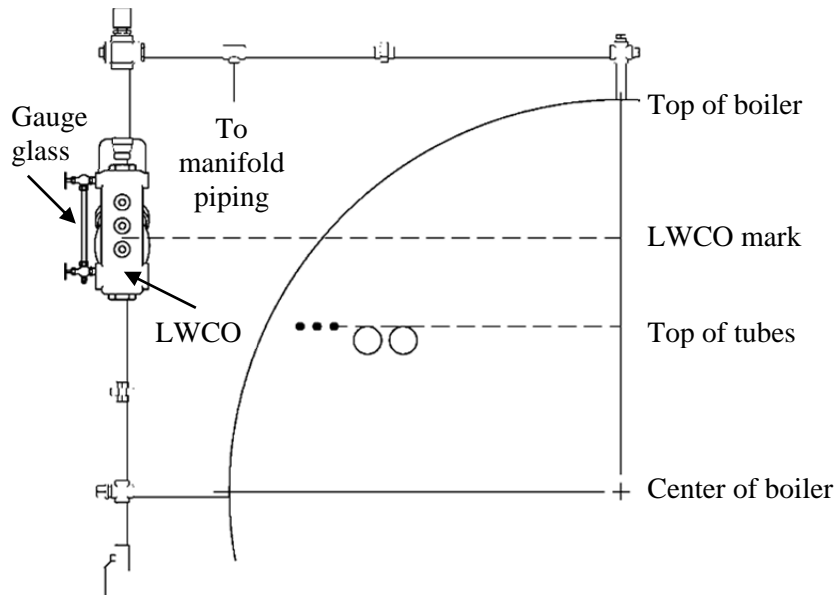

Typical steam water column, **Figure 8**

3.4 Typical basic pressure and temperature controls

Controls have pigtails for siphon loops.

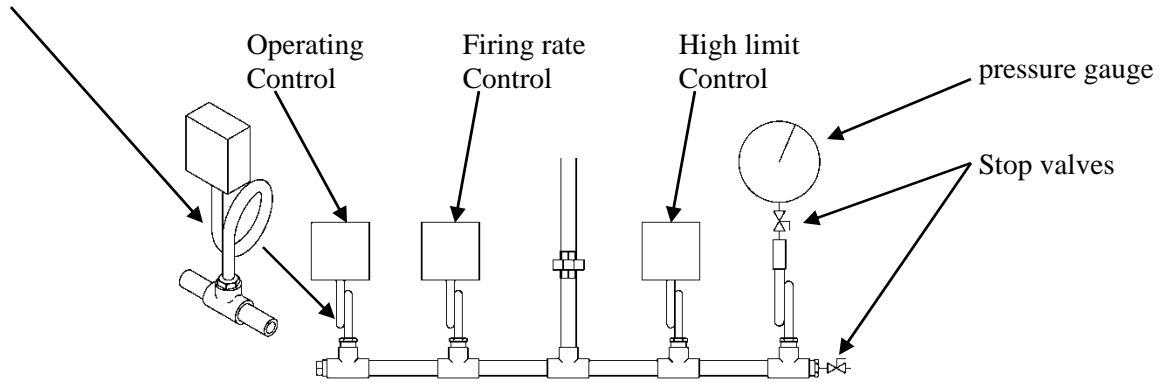

Typical pressure manifold, **Figure 9**

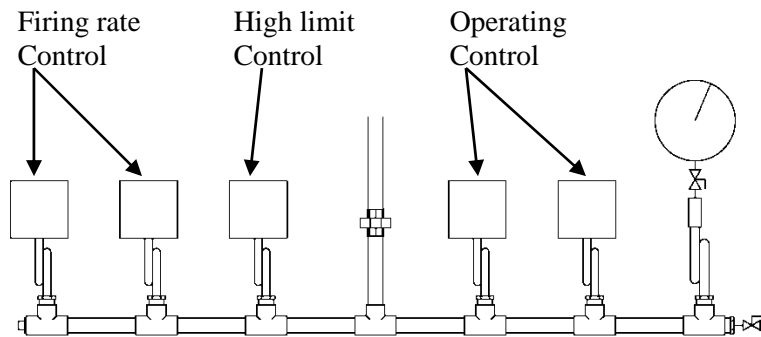

Example of pressure manifold w/ day night controls, **Figure 10**

3.5 Water level controls

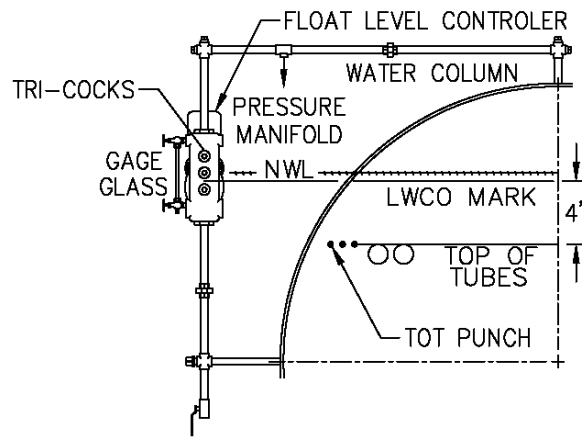
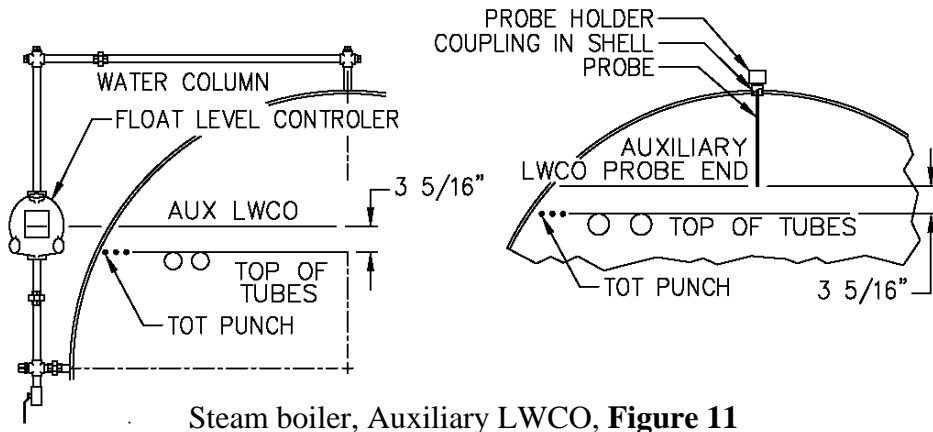

3.6 Typical temperature & pressure controls, Figure 13

STEAM BOILER

PRESSURE MANIFOLD

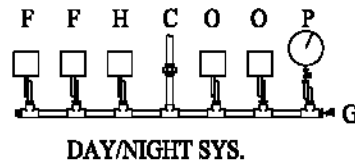
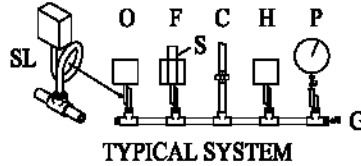

PRESSURE MANIFOLD

- P: PRESSURE GAGE W/COCK
- H: HIGH LIMIT (PRESSURE SWITCH)
- O: OPERATOR (PRESSURE SWITCH)
- F: FIRING RATE (PRESSURE MODULATION)
- G: INSPECTOR'S GAGE COCK
- C: CONNECTION TO WATER COLUMN
- S: PRESSURE SENSOR*
- SL: SIPHON LOOPS
- LF: LOW FIRE HOLD (AQUASTAT)*
- MT: MINIMUM TEMPERATURE (AQUASTAT)*

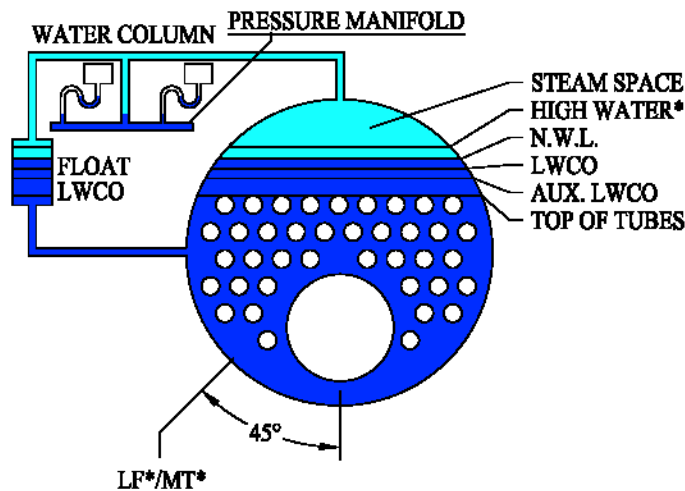

NOTES:

*=OPTIONAL OR SPECIFICATION DEPENDENT

LWCO: LOW WATER CUTOFF
TOT: TOP OF TUBES

3.7 Smoke Box's, Figure 14

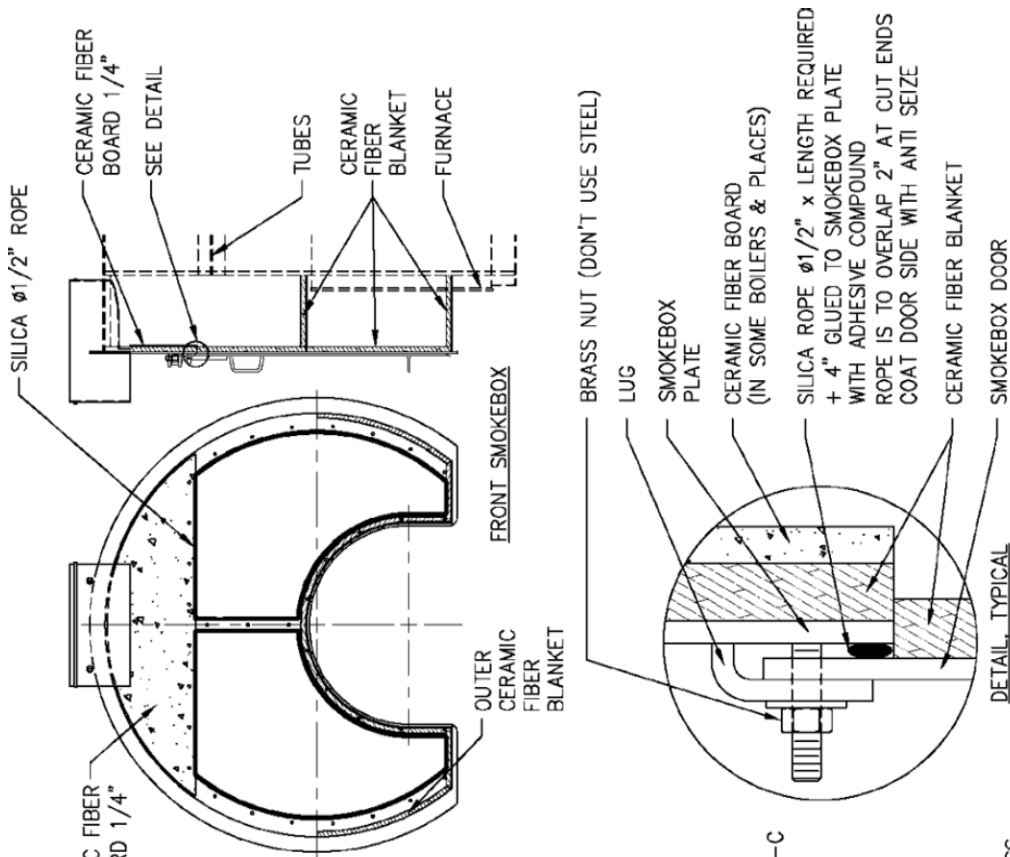

- DETAIL, TYPICAL SMOKEBOX GASKET INSTALLATION**
- NOTES:**
1. SILICA ROPE, CERAMIC BLANKETS, AND FIBER BOARD RATED FOR 1200° MIN.
 2. APPLY ADHESIVE TO SMOKEBOX PLATE TO HOLD ROPE IN PLACE.
 3. INSTALL 1\" CERAMIC PLANKET AS SHOWN TRIMMING TO FIT UPON INSTALLATION.
 4. USE CUP HEAD PINS ON APPROXIMATELY 8\" CENTERS ON CERAMIC FIBER BLANKETS.
 5. COAT ALL GAS EXPOSED 1\" CERAMIC FIBER BLANKET WITH RIGIDIZER.

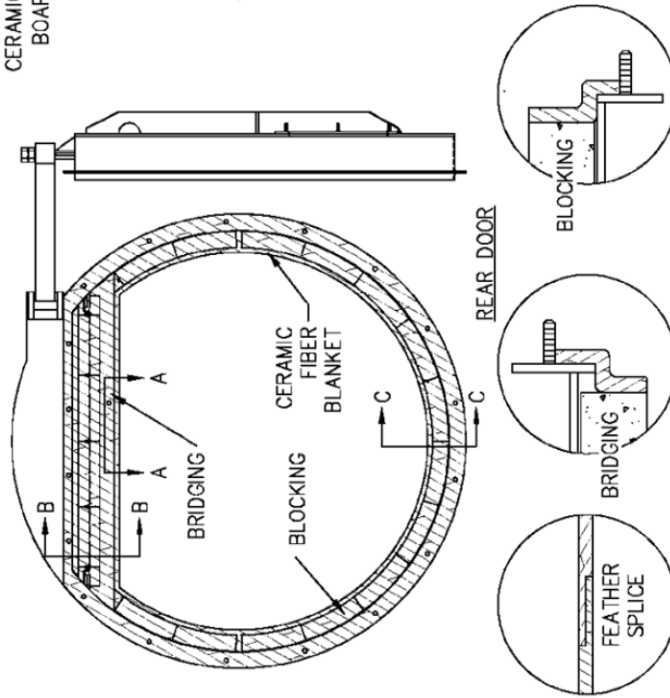

- REPLACEMENT & INSTALLATION OF REAR DOOR SEAL**
1. REMOVE OLD GASKET MATERIAL, EXPOSING BRIDGE & BLOCKS (B&B)
 2. CHECK EVENNESS OF OUTER FACE OF B&B AND REPAIR AS NEEDED.
 3. APPLY 1\" CERAMIC FIBER BLANKET TO THE OUTER FACE OF THE B&B USING SPRAY ADHESIVE. DO NOT APPLY TO REAR DOOR FLANGE.
 4. FEATHER LAP THE EDGES OF BLANKETS AS SHOWN IN SECTION A-A TO PREVENT UNEVEN THICKNESS IN THE BLANKET
 5. CLOSE THE REAR DOOR MAKING SURE IT CENTERED WITHIN THE STUDS.
 6. INSTALL LUGS AND CLAMPS, TIGHTEN EVENLY TO ABOUT 1/4\" THICKNESS.
 7. TRIM AND REMOVE EXCESS BLANKET AROUND DOOR PERIMETER.
 7. AFTER BOILER ON LINE, CHECK FOR LEAKS.
 7. TIGHTEN ONLY AS REQUIRED TO ELIMINATE LEAKS.
- 2 PASS DRYBACK REAR AND SMOKEBOX DOORS GASKETS, BLANKETS, & BOARDS INSTALLATION DRAWING

3.8 Cleanout plug (70HP & larger)

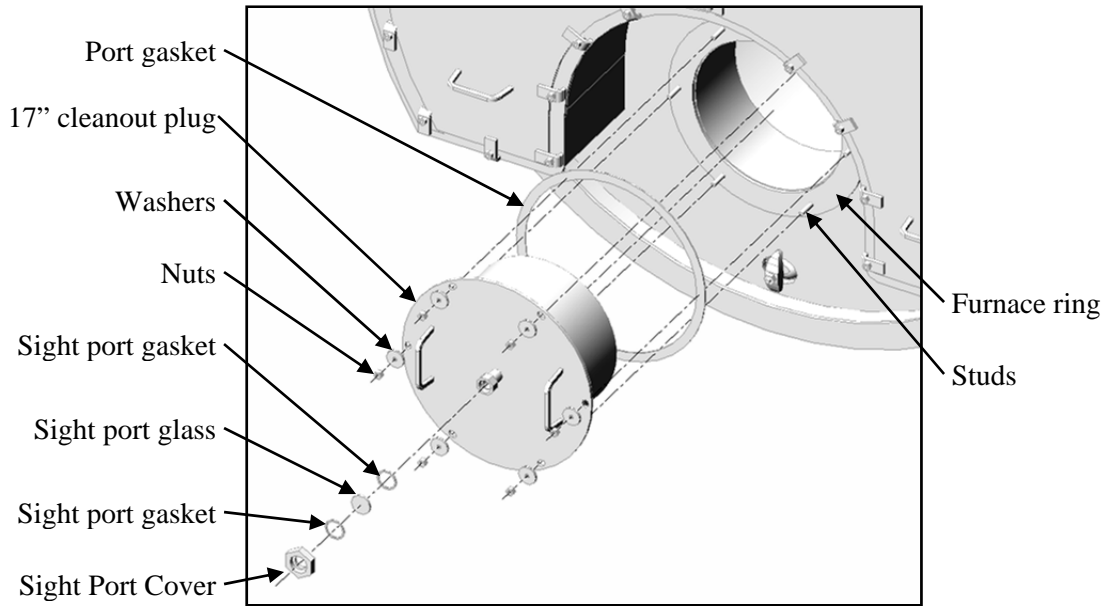

Cleanout plug, Exploded view: **Figure 15**

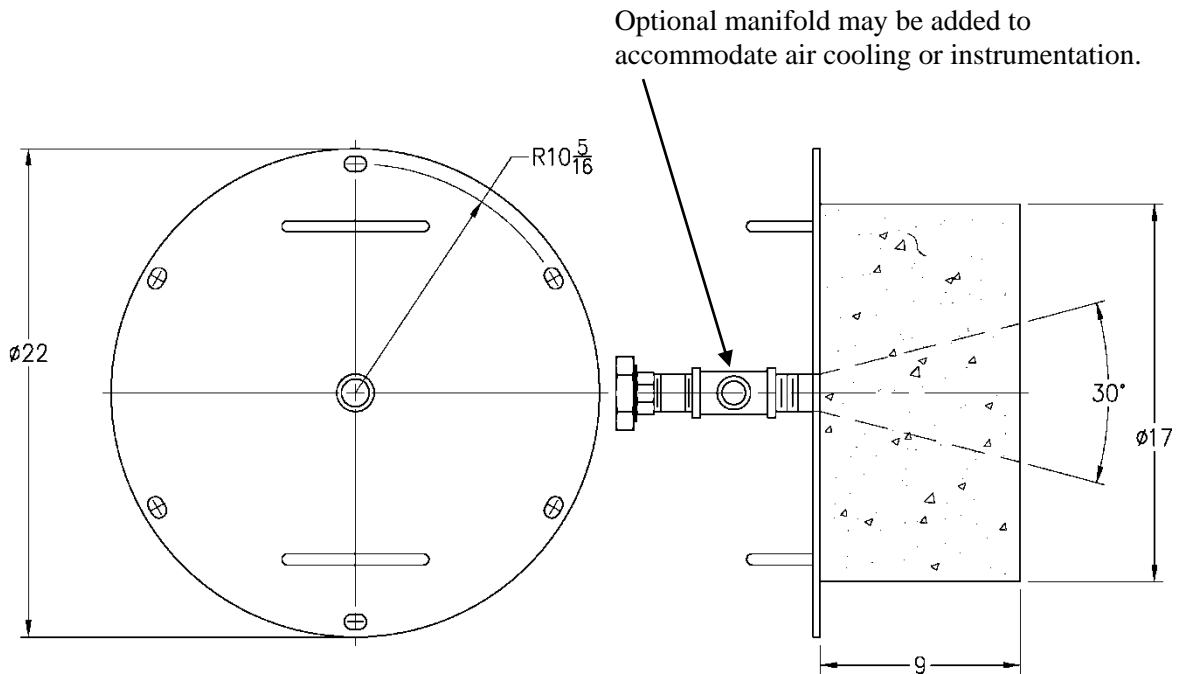

Cleanout plug, Drawing w/ optional tee: **Figure 16**

3.9 Burner mounting

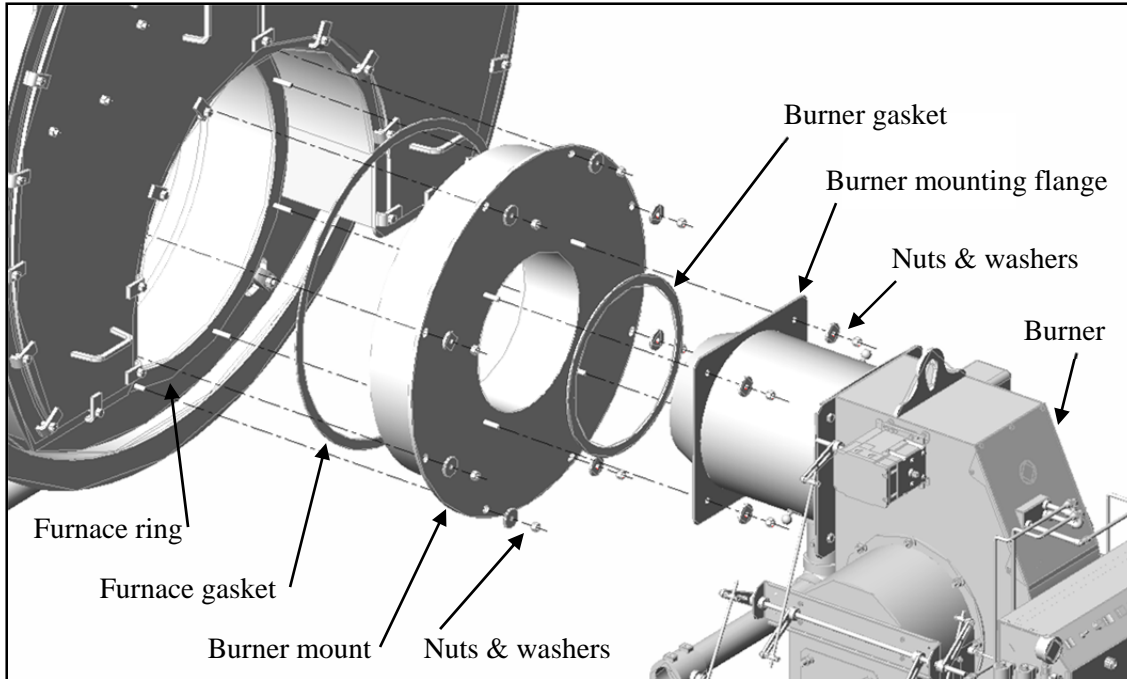

Burner mounting on boiler, exploded view: **Figure 17.** Also see **Figure 20**

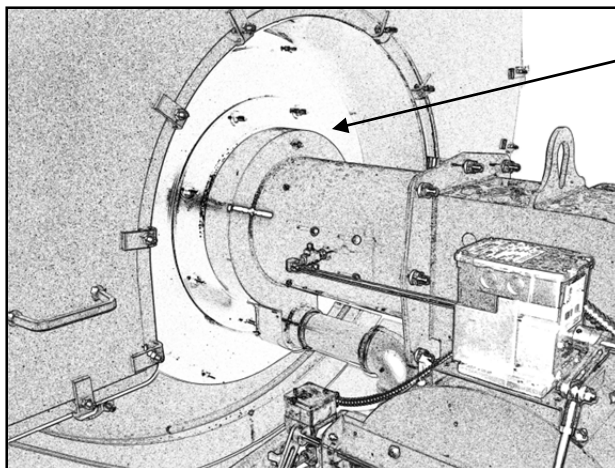

Mounted burner: **Figure 18**

Structurally, each burner mounts differently. Shown here is a burner that is supported with a pipe that includes a union to free the burner from the support. Either bolts or union(s) will be provided to structurally remove a burner

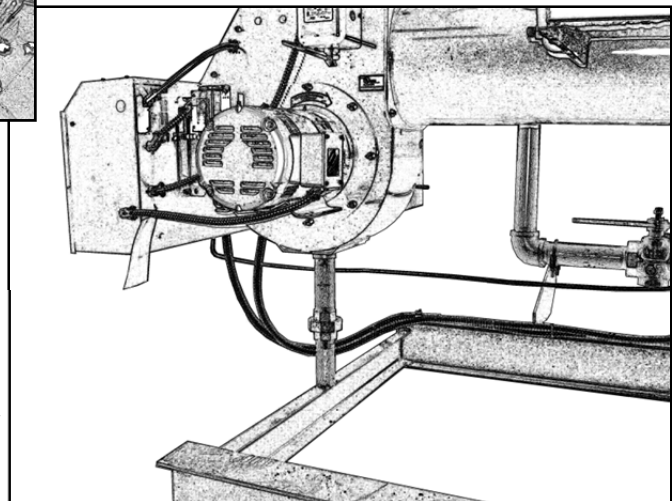

Burner mounting, Structural: **Figure 19**

3.10 Burner mount packing

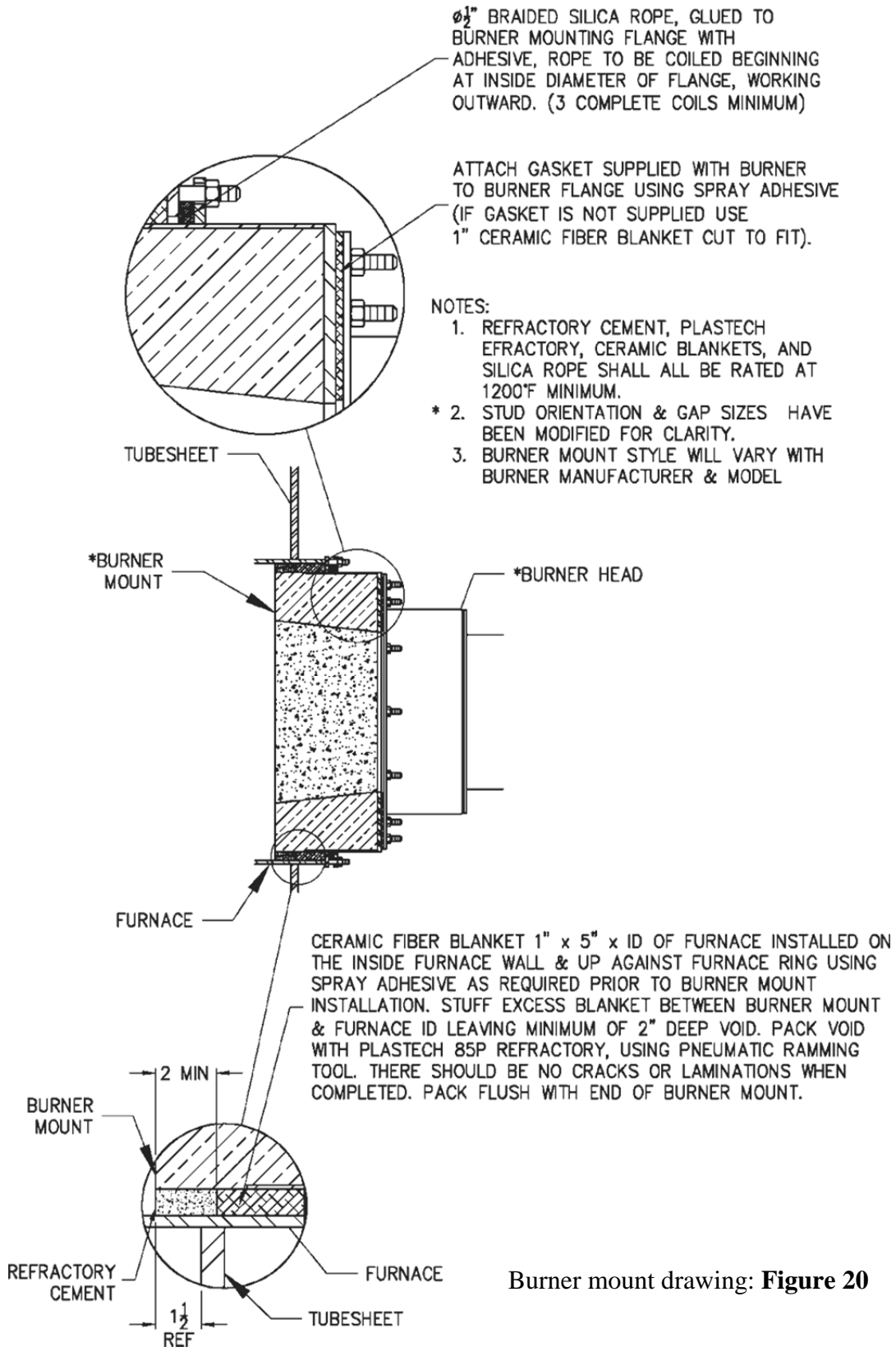

Burner mount drawing: **Figure 20**

3.11 Feedwater piping

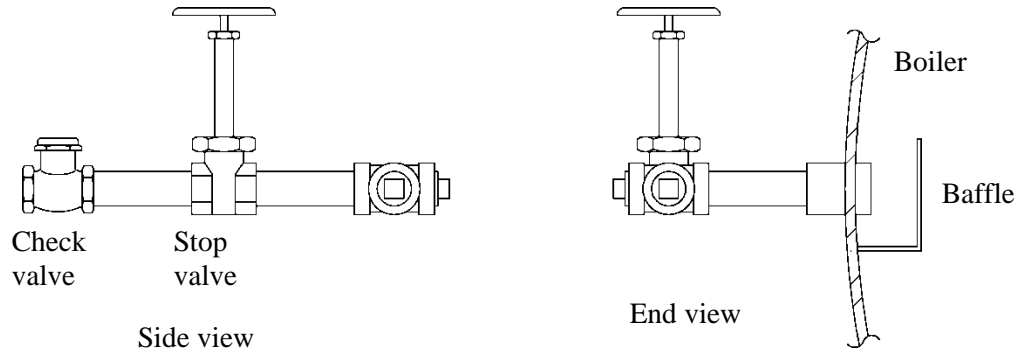

Basic feedwater valves, **Figure 21**

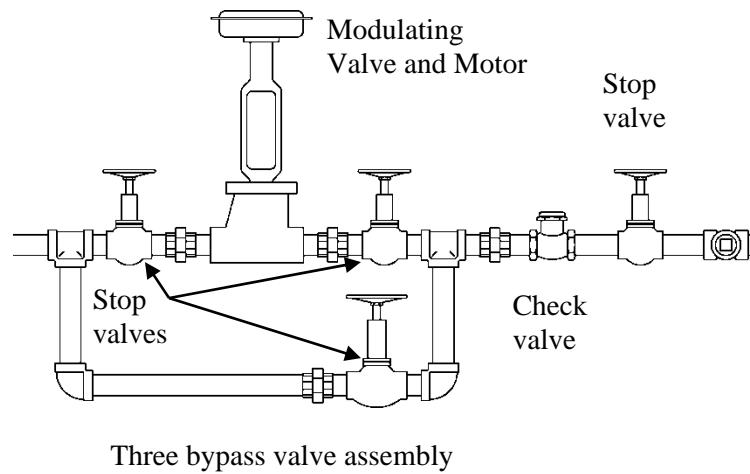

Example of feedwater piping with 3 valve bypass. **Figure 22**

3.12 Hand holes and Manway

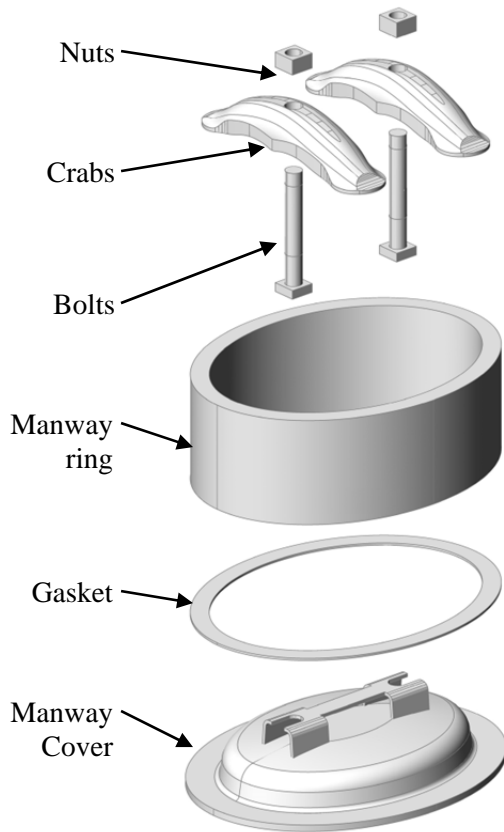

Manway assembly, **Figure 23**

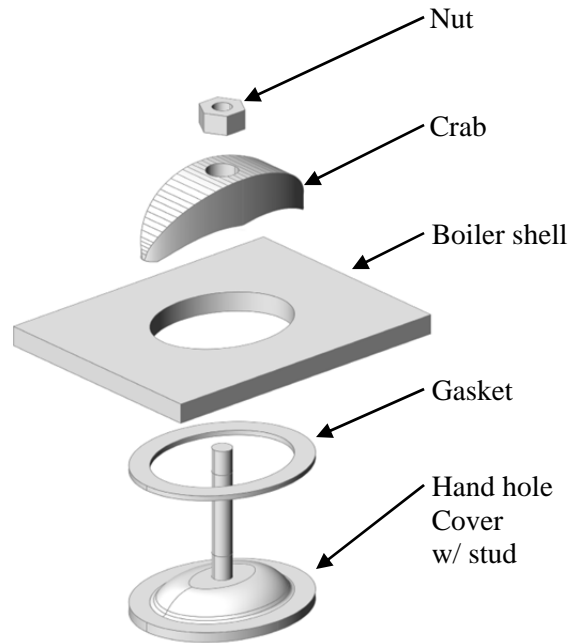

Hand hole assembly, **Figure 24**

Different gaskets are designed for various temperatures and pressures. All gaskets can be effected by a relationship between temperature, pressure, and Oxygen. If very low oxygen content is present in the steam, trouble rarely arises with a properly mounted gasket inside the boiler. From the exterior, the true difficulty arises. Here we see edges of the gasket beyond the cover plate. This gasket is exposed to the highly corrosive attack of air that is 18% oxygen. The air adjacent to the gasket is near the temperature of the steam. The rate of rubber deterioration is also in proportion with the pressure the gasket is under. If you can reduce any of the three things that accelerate the corrosion of the gasket (Temperature, pressure, and oxygen), then and you reduce the rate at which it deteriorates. The best thing you can do to help this it minimize the pressure on the gasket. This is done by starting with hand tight, then 1/4 turn with a wrench. Then only tighten as is required to prevent leaking. When you close inspection openings, make sure the cover and gasket are well centered.

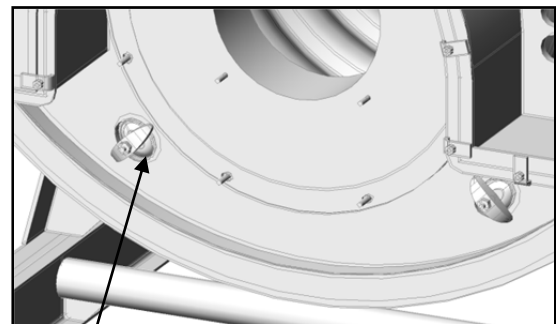

Exposed boiler drum
One of the few places drum temperature can be taken

Front tubesheet w/ Hand hole installed:
Figure 25

3.13 Miscellaneous images

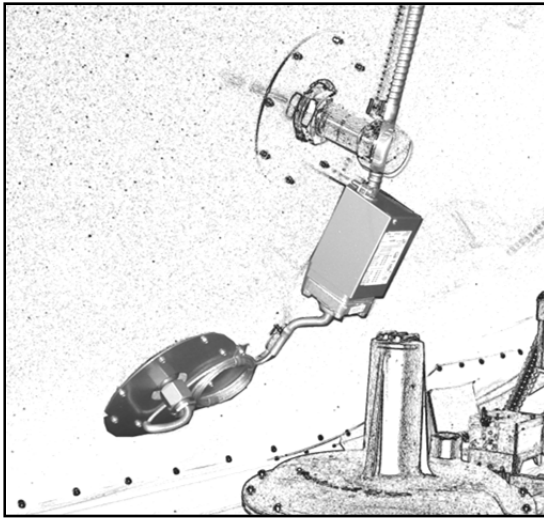

Low fire hold or
Minimum temperature:
Figure 26

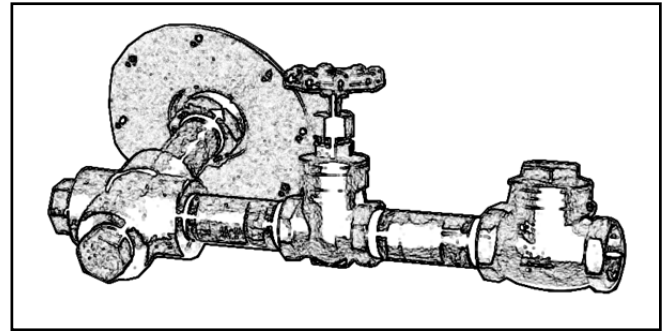

Chemical feed valves: **Figure 27**

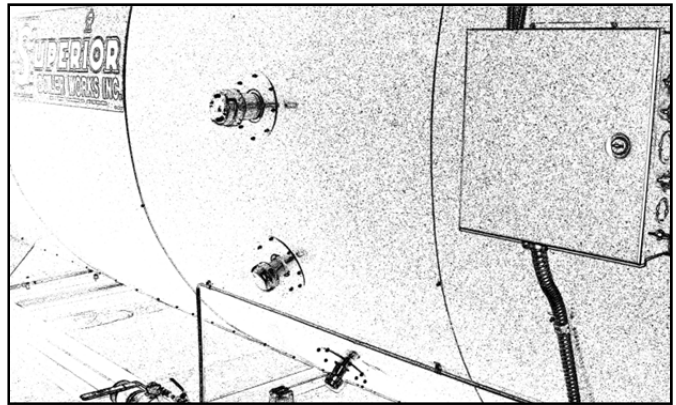

Unused capped connections: **Figure 28**

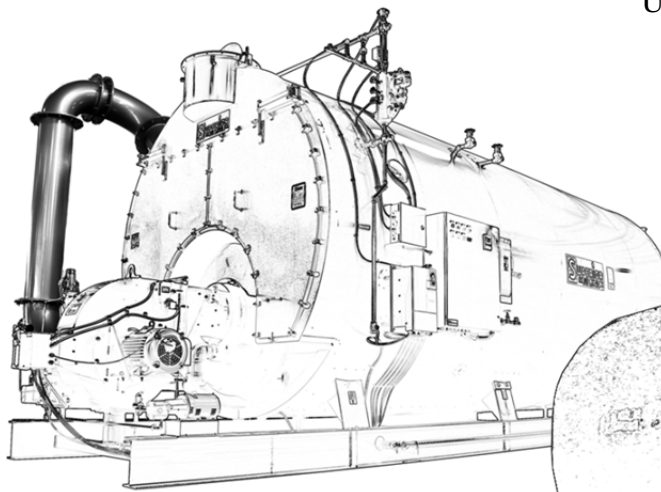

Example flue gas return: **Figure 29**

Flue gas return can be taking out of the front smokebox either from the top or front of the boiler depending on the exact configuration.

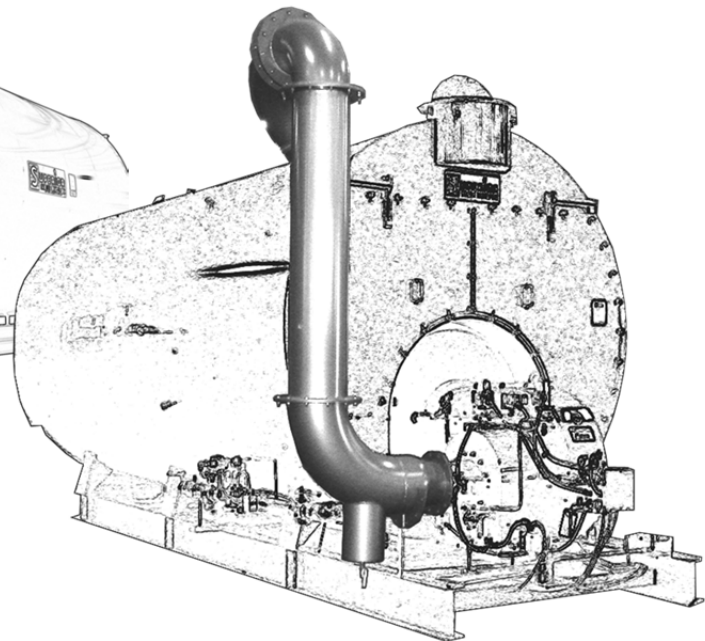

Example flue gas return (same boiler as fig 32): **Figure 30**

3.14 Safety Valves

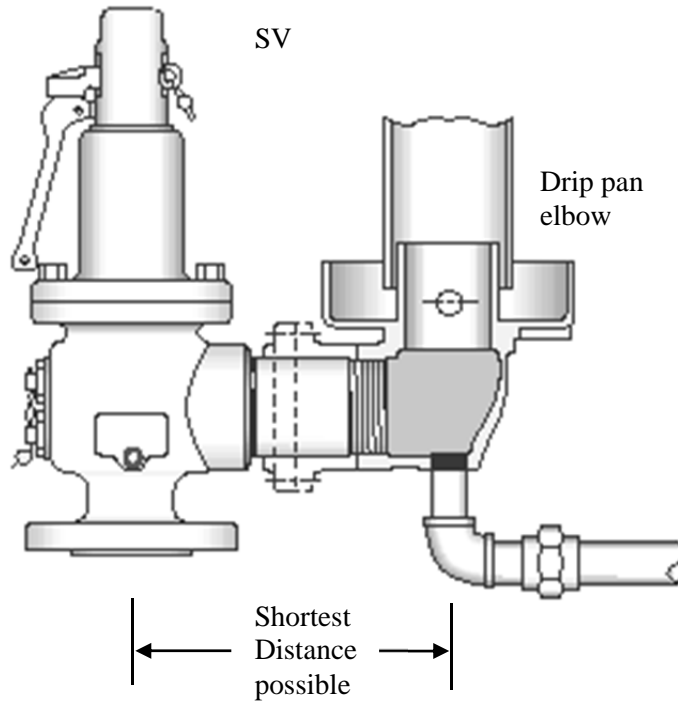

Safety valve (SV): Figure 31

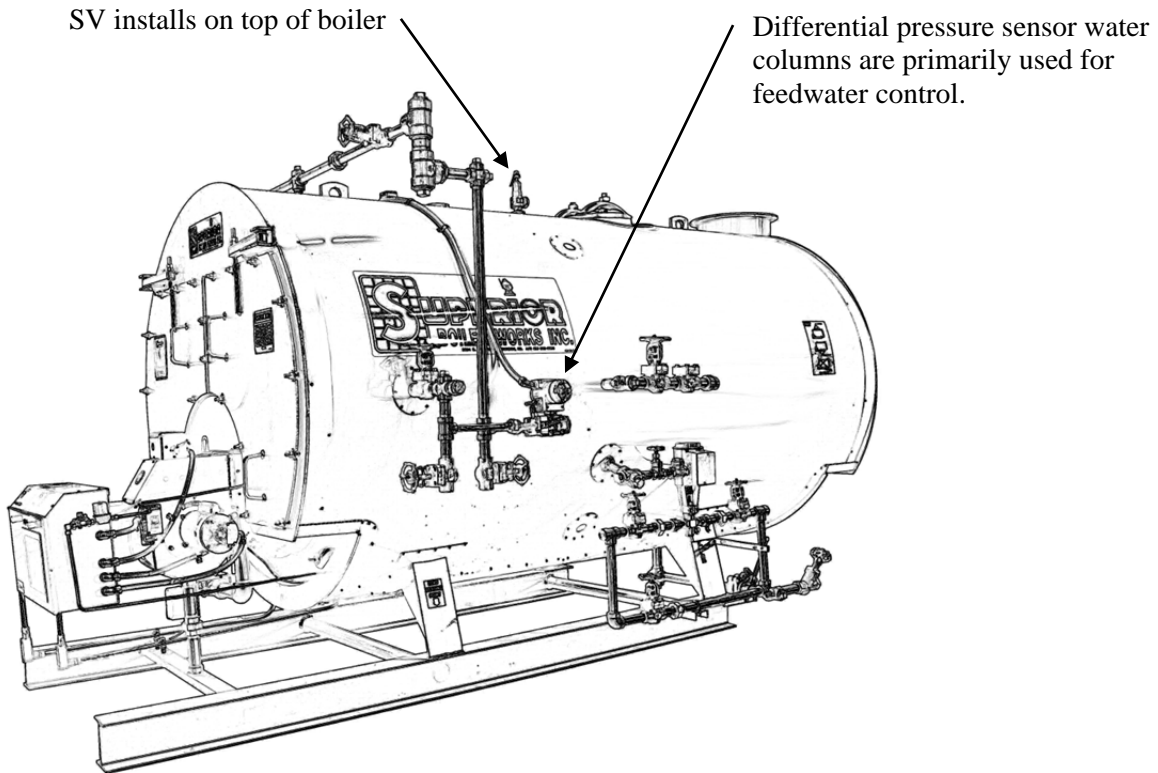

Boiler with SV and differential pressure sensor: Figure 32

3.15 Blowdown valves



Blowdown valves, single connection: **Figure 33**

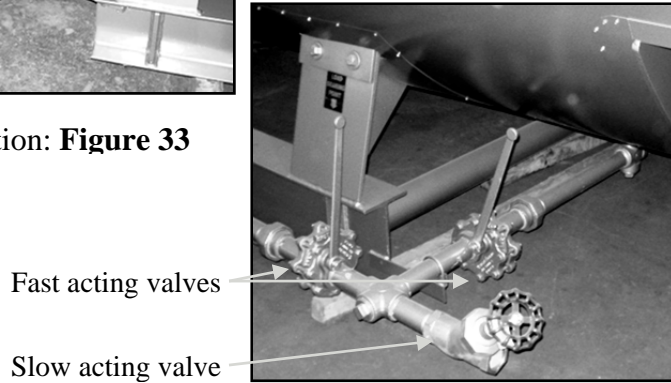

Blowdown valves, two connections: **Figure 34**

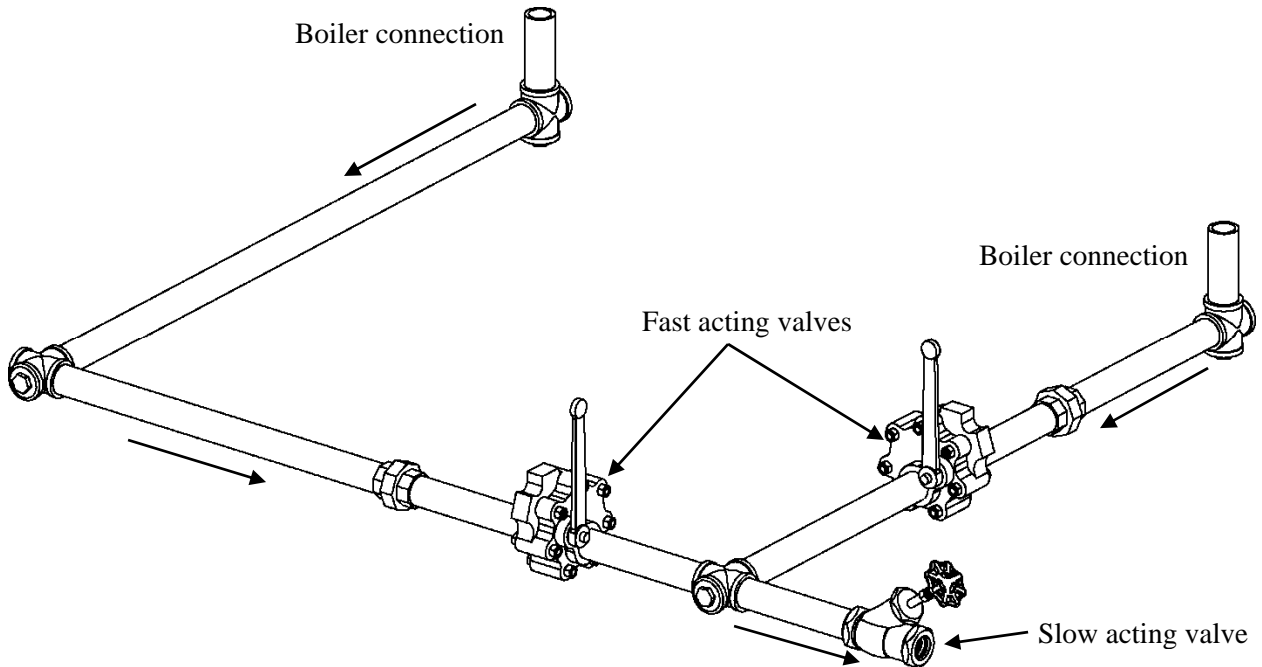

Blowdown valves, two connection drawing: **Figure 35**

3.16 Surface blowdown systems

Skimmer pipe rendering:
Figure 36

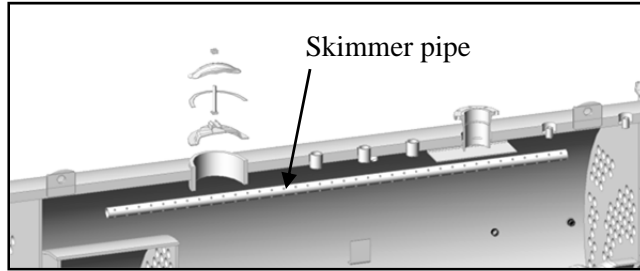

Skimmer pipe drawing:
Figure 37

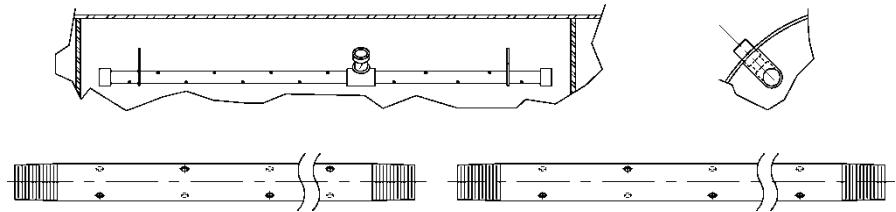

3.17 Miscellaneous images

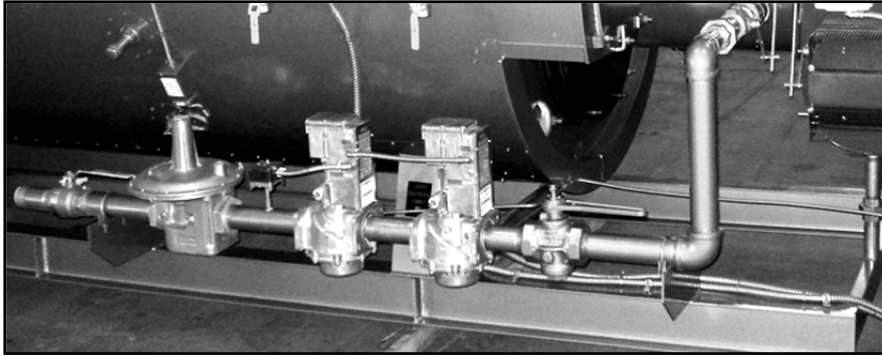

Example fuel train: **Figure 38**

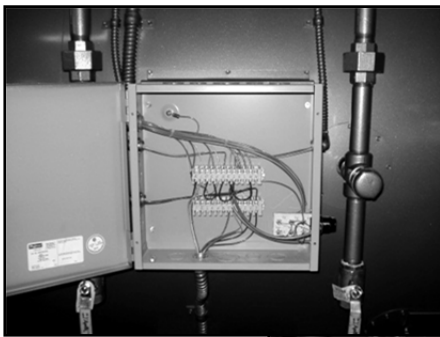

Example 12" x 12"
junction box
With terminal
strips
Figure 39a

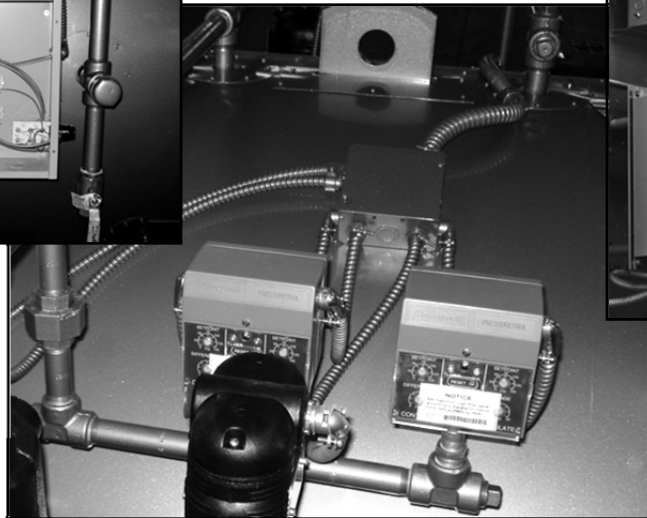

Example 4 x 4 junction box **Figure 39b**



Example of multiple
junction box's including:
Burner control panel,
power disconnect, VFD
controller, and junction
box, **Figure 39c**

Examples of electrical panels & junction box's: **Figure 40**

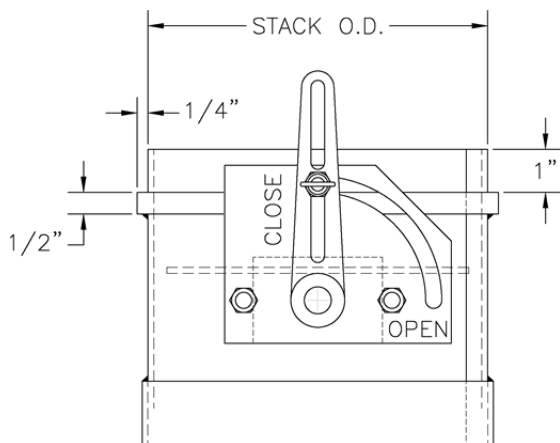

Stack connector, slip fit: **Figure 41**
Shown with locking quad option.

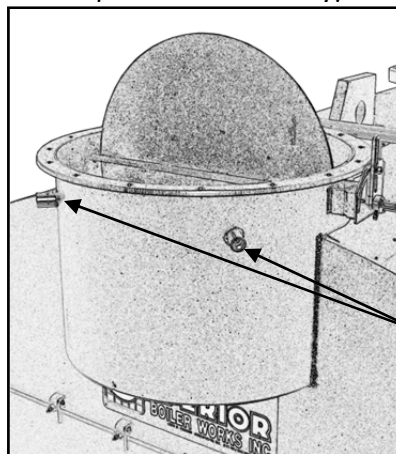

Temperature
gauge
connections

Stack connector, flanged: **Figure 42**
Shown with locking quad option.

3.18 Example fuel train schematics, Figure 43

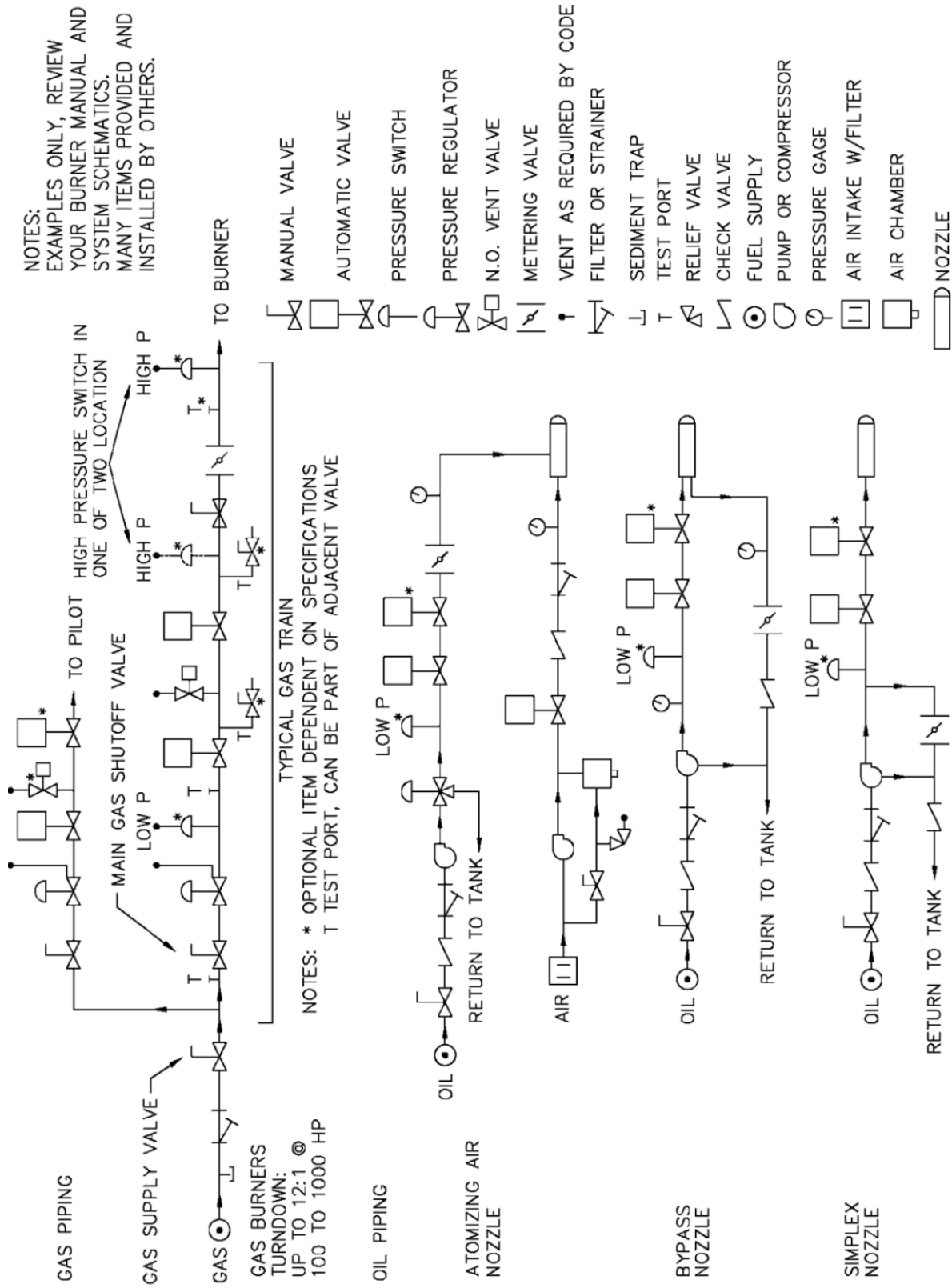

EXAMPLE FUEL PIPING

4.0 SPECIFICATIONS

Superior Boiler Works Inc. (SBW) Steam dryback scotch marine boilers are two or three pass. Sizing is based on a minimum five square feet fireside heating surface per boiler horsepower (BoHP) output.

The boiler is mounted on a structural steel base with a forced draft burner and burner controls. The steel base includes extended runners on the front to provide burner support and protection.

The boiler is designed, constructed, and tested in accordance with the latest edition and addenda of the ASME boiler and pressure vessel code. The boiler is registered with the National Board of Boiler and Pressure Vessel Inspectors.

The boiler is completely pre-assembled and tested at the factory to check construction, controls, and combustion characteristics of the unit.

Boilers smaller than 300 BoHP are constructed to meet CSD-1. Boilers 300 BoHP or larger are constructed to meet NFPA 85.

Boilers are equipped with two lifting lugs capable of safely supporting the packaged boiler's weight during lift operations.

The Furnace is located in the bottom third of the boiler to provide for the maximum heat transfer while being in contact with the coolest boiler water. Boilers constructed to Section I of the A.S.M.E. Boiler and pressure vessel code are to have a furnace of the Morrison corrugated design. Boilers constructed to Section IV of the Boiler and pressure vessel code have a plain cylindrical furnace.

All tubes have a minimum wall thickness of 0.105" and are 2-1/2" O.D.

Turbulators are installed in all two-pass boiler tubes to enhance the convective heat transfer coefficient.

All tubesheets on a Section I boiler are to be a minimum of 3/4" to insure a tight seal between the tube and tubesheet. On a Section IV boiler, tubesheets of 100" diameter or less will be a minimum of 5/8", tubesheets larger than 100" diameter will be a minimum of 3/4" tube hole ligaments.

Front support legs are attached by welding. All support legs other than the front are attached by bolts and a slotted support to provide for expansion and contraction as the boiler warms and cools. The bolted legs are designed in a manor where the bolts secure position but do not support the weight.

All heating surfaces are fully accessible for inspection and cleaning without disturbing the burner equipment or opening smokebox doors. All boilers 400 Sq. Ft. or more have a 17" diameter access opening complete with a gasketed plug and a sight glass are provided to allow for access into the furnace. A threaded instrumentation manifold can be provided on the observation port for cooling and or instrumentation.

The front tubesheets are fully accessible for inspection or cleaning when the front doors are open. Opening of the access points, front and back, are not to be impeded by any fuel lines, door plates, baffles, linkages, or electrical connections. The front doors have davit hinges and are insulated with 1" thick ceramic fiber blankets. The insulating blankets have a K factor of 0.44 Btu/(hr• ft• °F) and are coated with a hardener to prevent erosion from the flue gasses. All doors are held in place by lugs that are secured by replaceable brass nuts. The door are sealed gas tight with non-proprietary ceramic fiber rope with a minimum density of 20 lbs. per square foot and a continuous use capacity of 1200 °F minimum.

Specifications (cont.)

The rear turnaround area, tubesheets, and refractory are fully accessible when the rear door is opened. The rear turnaround is to house the refractory blocks and bridge. The blocks and bridge are to be manufactured from high quality castable insulating refractory rated at 2600°F. The rear door refractory is to be poured from the same material as the refractory blocks and is to be “one piece construction” with no baffles. The refractory is to be held in place with anchors welded to the rear door.

The rear door is to be supported by an extra heavy-duty davit hinge that is capable of supporting the door when it is being opened or shut. The hinge is to be positioned so that the rear door will open to the right or left when viewed from the burner end.

The boiler shell is insulated with 2” thick 8 lbs. per cubic foot density mineral wool with a K-factor of 0.27 Btu/(hr• ft• °F) . The insulation is held in place by bands and is covered with a 22 gauge painted carbon steel jacket. All openings in the jacket have a trim ring. Optionally the jacket is stainless steel.

The entire boiler is painted with high temperature (500°F minimum) paint.

Hand holes and a manway are provided in accordance with the A.S.M.E. boilers and pressure vessel code. Two additional hand holes are provided to ease waterside inspection and cleaning in the front tubesheet near the bottom of the boiler either side of the furnace. A 12” x 16” manway is located along the top centerline of the boiler to facilitate water side cleaning and inspection when the boiler has more than 625 Sq. Ft. of heating surface. When installed, the top of the boiler furnace is visible when the manway cover is removed from the boiler shell.

A flue gas connection is located at the front of the boiler at the top centerline. The stack connection is either slip on or flanged. The flue gas connection is designed to support a minimum of #2000 of dead weight. The stack connector has a 1/2” NPT connection for installation of a stack thermometer. The stack connector can come with either a manual damper or sequenced draft controls.

Flue gas recirculation may be ducted from an additional outlet near the stack connector near the flue gas connection or ducted from breaching in the field. The lowest portion of this duct will contain an appropriately sized plugged connection to remove water if necessary.

Safety valves (SR) are selected and sized to the ASME boiler and pressure vessel code. Connections for SR(s) are provided along the top centerline of the boiler.

Connection 1” and larger not slated for use have an appropriate pipe nipple and cap installed.

Locations and sizes of many components are specified in the dimensional data and drawings.

4.1 Steam boiler specifications

Steam boilers come with water column connections on both sides of the boiler. Typically only one side's connections are used for the water columns.

A water column includes the primary LWCO, a pressure manifold, and a water column blowdown/drain valve (3/4" minimum). This and all water columns are 1" NPT pipe minimum.

A float type primary LWCO is provided with gauge glass, gauge glass valves, and try-cocks.

Any number of float or probe water level controls may be added. Probes may be added to the shell or in water columns. Float controls are only added to water columns. Additional Water level controls can be used for additional high or low water cutoff's or alarms. Additional water column(s) are added as required to accommodate the water level controls. Auxiliary connection(s) on the boiler may be added or upsized to accommodate controls. If more than two water columns are required, the location of some connection may vary to allow room of the additional connection(s).

A pressure manifold piped from the primary water column is supplied with a pressure gauge that can be isolated by a cock. An additional isolation cock is provided for use with an inspector's pressure gauge. The pressure manifold is piped to operate as a siphon loop. Siphon loops may be added to each device mounted on the pressure manifold.

A high limit (pressure) with manual reset, operating control, and modulating firing rate control are provided. Stop valves are not to be installed between the boiler and any of these controls.

The High limit, Operating, and Firing rate controls are installed as individual components on the pressure manifold. The firing rate controller can be replaced with a steam pressure sensor that is incorporated into the burners controls. The operator and firing rate controls can be incorporated into the same device. Multiple operators and firing rate controls can be used to accommodate day/night controls or other forms of multiple set points.

An auxiliary low water cut-off shall be provided. The standard is a probe type installed directly inside the boiler. Optionally, probes or float style may be used in a water column.

A high water alarm or cutoffs can be provided. The standard is a probe type installed directly into the primary LWCO water column piping. Optionally probes or floats may be used in a water columns or probes inside the shell. High water alarm or cutoff is installed at 1" below the top of gauge glass.

Two feedwater connections on the horizontal centerline shall be provided, one on each side of the boiler. Each connection shall be furnished with an internal baffle.

A feedwater control of either on/off or modulating type is installed. This is either a separate control or part of the primary LWCO device.

Feedwater piping shall be provided with a check valve and manual stop valve. The stop valve shall be located between the check valve and the boiler.

Feedwater control is either on/off or modulating. The Feedwater piping can be provided with a three valve bypass to simplify field plumbing. Typically the three valve bypass ships loose. The three valve bypass allows the modulating feedwater valve to be bypassed for manual operation.

4.1 Steam boiler specifications (Cont.)

A connection is provided in the bottom third of the shell of both sides. This connection can be used to add an aquastat used for low fire hold controls. This feature prevents the burner from entering high fire until the boiler has warmed up. An aquastat in one of these connections may also be used for a minimum temperature feature. The minimum temperature feature prevents the water inside the boiler from falling below a specified temperature.

The steam connection is an ANSI class 300# (Section I) or class 150# (Section VI) flange, except small boilers are equipped with a 3000# coupling.

SBW can guarantee 99% steam quality under typical operating conditions. High pressure boilers come standard with a dry plate, and low pressure boilers come standard with a Dry pan.

High pressure boilers optionally come with a dry pan in place of the dry plate.

The steam nozzle may come with a stop and non-return valve. The steam nozzle may also come with a spool to adapt the standard nozzle size to the valves required for field installation.

The Boiler shall have at least one drain/blowdown connection. Two are provided on boilers 200 HP or larger.

Section IV boilers are to be supplied with one factory piped and installed slow opening blowdown/drain valve. Section I boilers are to be supplied with one factory piped and installed quick opening blowdown valve per blowdown connection, and one slow opening valve per boiler.

A 1" surface blowdown connection with a dip tube is provided on both sides of the boiler. The surface blowdown connections can optionally come with a full length skimmer in place of the dip tube. This can also come with a gate valve and calibrated metering valve.

The surface blowdown plumbing can be tied into an automated blowdown system and/or a sample cooler.

A standby steam heater can be added to the front of the boiler. This option is located in place of a front hand hole and moves that hand hole to an appropriate shell location. This hairpin style heat exchanger allows steam from another source to keep the boiler's water warm or at low pressure without turning on the burner.

A chemical feed connection can be supplied that is typically located between the low fire hold and feedwater connection. This connection can be equipped with a stainless steel diffuser and a stop and a check valve.

A vent connection is provided.

5.0 BOILER INSTALLATION

5.1 Receiving the boiler

During the construction of your new boiler, over one hundred (100) separate inspections were made of the unit. These inspections started with the engineering drawings that your unit was built to, and ended with the signing of the bill of lading by the freight carrier. These inspections were made by our Quality Control Department and our Insurance Inspection Agency. At the time the freight carrier signed the bill of lading at our factory, he acknowledged that the unit was received by him in an undamaged condition. It is good practice for you, prior to signing the freight carrier's delivery receipt, to examine your boiler in detail to be sure that the unit has not been damaged in transit. If damage is evident, make a notation on the freight bill of the damage and file a claim against the carrier for the cost of replacement or repair. In the event your boiler-burner unit should have sustained concealed damage (damage which is not outwardly evident), you have up to fifteen (15) days after receipt of the unit to file a claim covering repair or replacement of the concealed damage. Most of our units are shipped with certain fragile and easily damaged parts packaged in a separate box. The freight bill will describe the number of pieces shipped. Be sure that all pieces noted on the freight bill are received.

Boilers are typically shipped with the main boiler burner package assembled with fuel train(s), mounted switches, and wiring that's practical before placement. Electrical components are wrapped in plastic, and the boilers internals are closed off from the elements. The shipped condition is only intended to protect the boiler from weather during transport, not additional long term storage. Some parts are shipped loose with the boiler. Boil out chemicals, if purchased from SBW are shipped separately.

5.2 Unloading the boiler-burner unit

Your new boiler-burner unit is equipped with lifting lugs, located on the top center line. These are to be used for unloading. A crane is the best means of unloading and setting the new unit in place. Dollies placed under the legs can also be used to move the boiler on flat surfaces. ***DO NOT USE A LIFTING CABLE AROUND THE UNIT. DO NOT USE A FORK LIFT UNDER THE DRUM OF THE BOILER.***

See Figure 1-7

5.3 Boiler unloading instructions

- Before the boiler is shipped, employ a firm that is experienced in the unloading and moving of equipment of this size and weight.
- Confirm with the supplier of the crane that is being used to unload the boiler that it is of sufficient capacity to lift and unload the boiler. The boiler's dimensions and weights are found on the R&D drawing supplied with your submittal.
- Upon arrival, inspect the boiler and any parts shipped with the boiler. If any damage is found, notify Superior Boiler Works Inc. and note damage on the bill of lading and any other receiving papers.
- The boiler is designed to be lifted by the lifting lugs only. The use of tow motors, etc., is not acceptable and can damage the boiler. **See Figure 1-7**
- Before lifting the boiler, check all of the transport tie downs to insure that they have been removed and will not interfere with the lifting of the boiler.
- Check the lifting cables to insure that they are positioned properly and will not cause any damage to the boiler.
- Check all Smoke box doors, electrical enclosure doors, and attached piping to insure that they are firmly secured.
- Carefully lift the boiler off the trailer, lower it and transport it to its installation location.
- Lower the boiler onto its foundation and disconnect the lifting cables.
- With the boiler is in position, verify that required clearances are satisfied. Clearances need to be provided from combustible materials, for access openings including smokebox doors, and for re-tubing. **See Figure 1-1** This should be checked while the boiler can still be easily moved.
- The boiler should now be in position for the attachment of all the connecting piping and electrical wiring.
- If the boiler cannot be moved into position by the crane, it may be lowered onto a set of trucks and then rolled into position. The trucks must be designed to support the weight of the boiler. The trucks must be placed directly under the legs of the boiler.
- The boiler is to be rolled into position by attaching a set of cables to the rear legs of the boiler and the other end to a winch. Using the winch, pull the boiler into location. NOTE: Do not attach the winch to a load-bearing wall or column. If the boiler is to be set on a housekeeping pad, the truck height and pad height should match closely. If there is a height mismatch, boiler damage can occur.
- After the boiler has been located, the rollers can be removed by one of two (2) ways. One is by lifting the boiler, again by the lifting eyes, and removing the rollers. The other is by jacking the boiler up and removing the rollers. It is highly recommended that if removal of the boilers requires the jacking up of the boiler, that boiler jacking pads be used. Any damage that could occur from the improper handling or jacking of the boiler is the responsibility of the equipment handler.

5.4 The boiler room

Local building codes and insurance requirements usually dictate the type of construction and the material to be used in the boiler room. The boiler room floor should be non-combustible and of adequate strength to support the weight of the boiler full of water. The boiler room floor should include a floor drain **See the “Drains” section**. It is advisable to provide, when possible, wall and floor surfaces that permit the use of water hoses. Space should be provided in the boiler room to accommodate the boiler’s feedwater equipment, boiler water treatment equipment, fuel oil pumps, and any other equipment that may be required in the boiler room. Space should be provided at the rear of the boiler to completely open the rear door. Adequate space should be provided around each boiler to permit cleaning and inspection of all piping supplied with the boiler.

Fresh & Ventilation air

The boiler room must have an adequate air supply to permit clean, safe combustion and to minimize soot formation. An unobstructed air opening should be provided. It may be sized on the basis of 1 sq. in. free area per 2000 Btu/hr maximum fuel input of the combined burners located in the boiler room, or as specified in NFPA 31, 54, 85 or IFGC as applicable to your installation. The boiler room air supply openings must be kept clear at all times. Also review the ventilation requirement of your burner.

Lighting

The boiler room should be well lit and it should have adequate emergency lighting for use in case of power failure. If a flashlight is used for this purpose, it should be maintained in usable condition and it should be protected against removal from the boiler room.

5.5 Setting the boiler

After the boiler has been set in place, it is necessary to be leveled. The tubes inside are the component of the boiler that is most desirable to have level. The legs at the front of the boiler are fixed. All other legs are designed to allow the boiler to expand and contract as the boiler heats and cools. Once the boiler has been permanently installed and leveled, the skid bracket bolts should be loosened half a turn, but no more than one full turn, to allow for expansion of the boiler during operation.

5.6 Extended storage procedure for boilers not yet installed.

NOTICE!

If a newly delivered boiler is to be placed outdoors for more than two weeks, the following steps shall be taken:

- The boiler should be placed on crossties under the legs, preferably on a flat surface of concrete or asphalt.
- Make certain that any moisture from weather has been removed.
- Remove the manway cover and place desiccant on the uppermost row of tubes.
- The electrical enclosures and panels will also require desiccant to protect against condensation. A handful's worth of desiccant in a cardboard lid will do.
- Close the unit up tight to exclude all moisture and air.
- Desiccant should be checked weekly. When the desiccant has changed color, it is used up. Replace as required.
- The entire boiler should be covered with a tarp, with emphasis on protection for the gas train, oil pump, air compressor, low water cutoff, junction box's, burner control panels, and boiler control panels.

For the water side of a boiler, SBW recommends a desiccant product called boiler lizards. These tubes of desiccant can be opened and placed in the water side of a boiler. The boiler lizards can remain in the water side of the boiler to be dissolved by water. The desiccant and tubular bags are water soluble; dissolving the first time water is added to the boiler. Desiccant placed in other locations should be removed prior to placing the boiler in service. Even if the extended storage is inside, this extended storage procedure is recommended.

5.7 Installation of Loose shipped items

Once the boiler is set, loose shipped items can be installed and the boiler can be connected to your systems. It is preferable to delay installation of any items with glass like gage's until after the piping has been completed to avoid glass breakage.

Items that typically ship loose are: †May be mounted, depending on configuration

- touch up paint
- Safety valve(s)
- Water gage glass †
- Pressure gage
- Stack thermometer
- Gaskets and bolts between any steam outlet parts
- Feedwater three valve bypass
- Flue gas return piping †

Many components like gages, water gauge glass, and gaskets will have their own manuals. Please refer to the appropriate documentation for installation.

At least one small parts box will be supplied with your boiler for small items like pressure gauges, thermometers, and any other small lose items you ordered. Larger and heavier items are typically shipped on pallets.

For steam boiler, an appropriate pressure gauge is provided; install this on the pressure manifold.

See Figures 9 &10

An appropriate stack thermometer is provided. Install into a 1/2" coupling provided in the stack connector. **See Figure 42** Note: Installer must add a plug to the side not used.

The safety or safety relief valve(s) shall be installed connections provided on the top of the boiler. Often this is takes place after the boil-out procedure. The safety or safety relief valve(s) provided for your boilers are documented in the ASME data reports provided with this manual.

See Figures 31 32. Also see the Safety valve installation section

If your system includes a loose shipped flue gas return system, the ducts will be shipped on pallets. Bolts or studs, nuts, will be provided in the small parts box(s). Gaskets are either provided already on the ducts or in the small parts box(s). The Ratings and Dimensions drawing for your system will show the arrangement of your flue gas return duct. Attach the flue gas return ducts from the provided flue gas connection near the stack outlet to the flue gas return connection on the burner. Any required duct supports or attachment points will already be in place.

5.8 Electrical Installation

WARNING

The improper installation, adjustment, service, maintenance, or operation of this equipment can result in fire, explosion, series injury, or death.

ELECTRICAL INSTALLATION SHALL BE IN ACCORDANCE WITH THE REGULATIONS OF AUTHORITIES HAVING JURISDICTION.

A wiring diagram for the boiler will be in the junction box. A wiring diagram for the burner will be inside the burners' control panel. Those two wiring diagrams in conjunction with this manual, O&M manuals for the burner and electrical components, should provide an electrician with everything required to properly installing the electrical components. Before installing, modifying, or servicing system, main electrical disconnect switch must in the of OFF position. There may be more than 1(one) disconnect switch. Lock out and tag switch with a suitable warning label.

The exact configuration of electrical panels vary, the most common configuration includes a junction box near the primary water column or instrumentation cluster typically along the centerline of the boiler. Additional small junction boxes are used when needed. If for repair purposes, wiring is run to any probes, that wiring shall be sufficient for 150°F. Grounding of some components is conducted through the boiler and the mounting of burner to the boiler. Electrical power requirement are listed on placards for the respective components. Wiring from any boiler mounted controls are typically pulled to terminal strips in a primary junction box. The fuel train controls are typically pulled into the burners control panel. A common exception to this is if a pressure or temperature sensor is used for linkageless controls; these wire are typically pulled directly to the control panel depending on the configuration of the boiler. Wiring for sensors tend to be specific to the manufacture of the burner management system; if maintenance is performed on this wiring ensure the appropriate wire is used. Wires pulled to the junction box are mounted on terminal strips for ease of trouble shooting and maintenance. **See figure 39a**

Power for Electrically Operated Controls.

All controls are powered with a potential of 150 V or lower with one side grounded. A separate equipment ground conductor should be brought to the control panel frame with ground continuity assured to the fuel valve. All operating coils of control devices should be connected to the neutral side of the control circuit, and all control limit switches or contacts should be in the ungrounded (hot) side of the control circuit. If an isolating transformer is used, it should be bonded to the control panel frame. The equipment ground is not required when the isolating transformer is used. Do not fuse control transformers above their rated current value because these devices are current limiting and an oversize fuse may not blow under short circuit conditions.

Remote Emergency shutdown switches

A manually operated remote shutdown switch or circuit breaker shall be located just outside the boiler room door and marked for easy identification. Consideration should also be given to the type and location of the switch to safeguard against tampering. If the boiler room door is on the building exterior, the switch should be located just inside the door. If there is more than one door to the boiler room, there should be a switch located at each door. Where a boiler is located indoors in a facility and not in a boiler room, a remote emergency shutdown switch shall be located within 50 feet of the boiler along the primary egress rout from the boiler area. The installer shall be responsible to install the remote emergency shutdown switch(s) and to verify that it is suitably marked.

5.9 Miscellanies installation guidelines

Software & Safety

Programming controls, when used, shall provide proper sequencing of the above controls to insure that all conditions, necessary for proper burner operation, are satisfied. Included in a programmed control are pre-purge and post-purge cycles to remove accumulated gases.

Flame Safeguard

When installation is complete, Safety Controls will stop fuel flow in the cases of: ignition failure, main flame interruption, mechanical draft failure, circuit failure, as appropriate for your installation. The controls on the burner and boilers are designed to prevent fuel flow when any of the boiler conditions are outside intended limits of pressure, temperature, and water level as is appropriate for your system.

Compressed air

Air for Pneumatically Operated Controls shall be clean, dry, and available at adequate pressure. Particular attention should be paid to any plant air used in the burner if applicable.

Venting of Gas Controls.

Venting of gas controls should conform to recognized installation standards. It is best to check with the authorities have jurisdiction to determine your specific requirements.

5.10 Boiler stack connection

A flue gas connection is located at the top centerline at either the front or the back of your boiler depending on the design. The stack connection is either slip-on or flanged. The flue gas connection is designed to support a minimum of #2000 of dead weight. The breaching and chimney shall at minimum be the size of the boilers stack connector. When installing a boiler where the exhaust is tied into other systems, a professional should be consulted.

The stack connector has a 1/2" NPT connection for installation of a stack thermometer. A second 1/2" NPT connection is available for instrumentation, and will typically need to be plugged by the installer. SBW offers the following options for the stack outlet:

- Plain, no draft control built into the boiler.
- Stack damper, this is the rotating plate (a throttle). **See Figures 40,41**
- If you elect for a stack damper, there are two ways it is installed.
 - Locking Quad: for manually adjusting the damper.
 - Bearings: for attachment to a control system.

SBW also offers a sequenced draft controller to ensure electrical and mechanical compatibility of this portion of the stack control system as it ties into the burner controls.

INSTALLATION AND MAINTENANCE OF THE STACK SHALL BE IN COMPLIANCE WITH THE AUTHORITIES HAVING JURISDICTION.

Furnace pressure: The pressure drop between the burner and the stack connector at high fire.

Draft: The difference between the "stack effect" of your stack and the pressure drop of your stack. **Stack effect:** Flue gasses are hotter & buoyant compared to ambient air.

Both draft & furnace-pressure are measured at the stack connector, however it should be evident that the two terms have completely different meanings. This is typically measured with a Monometer (Supplied by others).

Your new boiler-burner unit is supplied with a forced draft burner capable of supplying all the air for combustion when operating at reasonable amount of draft. The boiler shall be connected to a vent having sufficient draft at all times to ensure safe and proper operations of the unit. For details on the relationship between draft and burner operation, refer to your burner manual or consult a professional. The furnace pressure (negative gauge value) should be between 0.03" and 0.6" WC at the stack connector.

Stack installation and adjustment are the responsibility of the installer. The installation of your venting system should be conducted by a professional installer who can properly balance the draft of your system with the tuning of your burner. Draft can dramatically impact the adjustment of your burner on a seasonal basis. Draft control is an issue at your discretion. Draft values and draft control vary depending on the configuration of your stack, weather conditions, firing rate of your boiler, and many other variables.

Some burner come with O₂ (Oxygen) trim controls that can help automatically adjust the balance of air flow for various firing rates and varying weather conditions.

5.11 Vent material selection

SBW recommends the use of type-L UL listed ducting systems installed by a professional contractor. Type-L is a UL listing category. The “L” stands for low temperature, defined as less than 1,000 degrees Fahrenheit in continuous operation. Type-L ducts are double wall construction with at least a one inch between the liner (inside wall) and a shell (outside wall). Single wall construction can be used, but the heat losses, potential fire hazards, and risks to people become problematic. A well insulated ducting system minimizes heat losses that can vary draft from varying weather conditions and minimize heat risks to personnel.

Materials:

- Liner for gas, liquid petroleum and #2 oil: stainless steel 304
- Liner for #6 oil: stainless steel 316
- The shell can be made from any corrosion resistant steel including: stainless 304, stainless 316, aluminized stainless or carbon, galvanized carbon or painted carbon. Painted carbon is not recommended unless you can get to every part of the duct after installation for maintenance. Specific selection is determined upon your environment, preferences, and local practices.

Thickness:

- Liner should be 20 gauge. Up to 36” diameter. 18 gauge over 36” diameter.
- Shells can vary from 26 gauges to 18 gauges depending on diameter, construction style, and structural installation choices. The UL Type-L listing process specifies an amount of incidental contact protection that is a good recommended standard.

Clearance:

- Single wall ducts require up to 18” of clearance from any flammable material
- Each manufacture of Type-L ducting will have a rating that specifies a require clearance to flammable material ranging from zero (0) to six (6”) inches.

5.12 Flue gas recirculation (FGR)

Packaged boilers can include flue gas recirculation. In this case, an additional flue gas outlet is added to the boiler’s smokebox as near as practical to the vent connector. In some cases the flue gas recirculation line will be shipped loose. If shipped loose, gaskets and bolts for use between sections of flue gas recirculation ducts will be included. The FGR duct will include a plug at its lowest portion to facilitate removal of water if required. Recirculation is typically controlled by an additional throttle at the inlet to the burner. **See Figures 29,30**

6 PLUMBING YOUR BOILER

WARNING

The improper installation, adjustment, service, maintenance, or operation of this equipment can result in fire, explosion, series injury, or death.

THE INSTALLATION OF THE UNIT SHALL BE IN ACCORDANCE WITH THE REGULATION OF THE AUTHORITIES HAVING JURISDICTION.

6.1 Fuel supply & connections

Gas piping shall be of adequate pressure at capacity for your applications in accordance with NFPA 54.

Fuel oil shall be stored, prepared and delivered to the fuel train under anticipated operating conditions in accordance with NFPA 31.

6.2 Boiler connections, general

- The configuration of the supplied piping is documented on your R&D drawing.
- ASME does require a gate valve on the outlet, and a non-return valve if two or more boilers are supplying steam to the same header.
- The piping on a boiler should be kept leak proof. A small leak, if allowed to continue, soon becomes a major problem.
- All vent and blowdown piping running vertically up should have means for draining the vertical run.
- Discharge from all blowdowns, safety relief valves, and venting shall be plumbed to a safe point of discharge. Please consult the authorities having jurisdiction to determine your discharge requirements.
- All of the plumbing installation of the boiler shall be in accordance with the regulation of the authorities having jurisdiction.
- Provisions shall be made for the expansion and contraction of steam and hot water mains connected to boilers so there will be no undue strain is transmitted to the boilers.

6.3 Water connections

A proper and convenient water fill connection should be installed and provisions should be made to prevent boiler water from back-feeding into the service water supply. Provision should also be made in every boiler room for a convenient water supply which can be used to flush out the boiler and to clean the boiler room floor.

6.4 Steam boiler feedwater connection

Baffles on feedwater connections of both sides of the boiler are provided. One elected side has the required stop and check valve. Feedwater shall only be introduced to the boiler through the feedwater connection with the required valves.

6.5 High pressure steam connections

Each discharge outlet, except safety valve, shall be fitted with a stop valve located at an accessible point in the steam delivery line, and as near the boiler nozzle as is convenient and practicable. When such outlets are over two inch (2") pipe size, the valve or valves used in the connections shall be of the outside screw and yoke, rising spindle type so as to indicate from a distance by the position of its spindle whether it is closed or open, and the wheel may be carried either on the yoke or attached to the spindle. A plug cock type valve may be used, provided the plug is held in place by a guard or gland, the valve is equipped to indicate from a distance whether it is closed or open, and the valve is equipped with a slow opening mechanism.

6.6 Two or more high pressure boiler steam connections

When boilers are connected to a common steam header, the connection from each boiler having a manhole opening shall be fitted with two (2) stop valves having an ample free flow drain between them. The discharge of this drain shall be visible to the operator while manipulating the valve. The stop valve shall consist preferably of one automatic valve of outside screw and yoke type or two (2) valves of the outside and screw and yoke type shall be used.

6.7 Drains

Unobstructed floor drains, properly located in the boiler room, will facilitate proper cleaning of the boiler room. Floor drains that are used infrequently should have a water poured into them periodically to prevent the entrance of sewer gasses and odors. If there is a possibility of freezing, and environmentally safe antifreeze mixture should be used in the drain traps. Drains receiving blowdown water should be connected to the sanitary sewer by way of an acceptable blowdown tank or separator or and air gap that will allow the blowdown water to cool to at least 140°F and reduce the pressure to 5 PSIG or less

6.8 Blowdown piping

Your new boiler is equipped with blowdown coupling(s) on the bottom centerline of the drum. On steam boilers, Surface blowdown connections are located at approximately two O'clock on both sides. The water columns, if supplied, are equipped with blowdown valves. Typically all of the blowdowns are piped together to a sewer drain discharge in the field.

6.9 Supplied blowdown valves

Section IV boiler are supplied with one factory piped and installed slow opening blowdown/drain valve. Section I boiler are to be supplied with one factory piped and installed quick opening blowdown valve per blowdown connection, and one slow opening valve per boiler. The piping is documented in the ASME Data Report. **See Figure: 38**

6.10 Blowdown connections

The discharge piping shall be full size to the point of discharge. When the blow off connection is located at the lowest water containing space, a separate drain connection is not required.

The minimum pressure rating of valves and cocks used for blow off or drain purposes shall be at least equal to the pressure stamped on the boiler but in no case less than 30 psi. The temperature rating of such valves and cocks shall not be less than 250°F.

6.11 Safety valves (SV)

See the operation instructions for more details on SV

SV need to be installed so that no significant loads are placed on the outlet. Testing and occasional weeping can create condensate. Drip pan elbows are recommended to handle these issues during installation. Safety valves are shipped loose because they are vital to safe operation and can be damaged during transport.

SV are installed to prevent operation of the boiler above maximum allowable working pressure. It is good practice to manually open the safety relief valves on your boiler monthly. This is done by lifting and releasing the handle provided on the valve. Refer to the maintenance section for details on use of these valves.

6.12 SV discharge piping

A discharge pipe shall be used. It's internal cross sectional area shall be not less than the full area of the valve outlet or of the total of the valve outlets discharge there into and shall be as short and straight as possible and so arranged as to avoid undue stress on the valve or valves. A union may be installed in the discharge piping close to the valve outlet. When an elbow is placed on a safety or safety relief valve discharge pipe, it shall be located close to the valve outlet downstream of the union.

The discharge from safety valves shall be so arranged as to minimize the danger of scalding attendants. The safety or safety relief valve discharge shall be piped away from the boiler to a safe point of discharge, and there shall be provisions made for properly draining the piping. The size and arrangement of discharge piping shall be independent of other discharge piping and such that any pressure that may exist or develop will not reduce the relieving capacity of the relieving devices below that required to protect the boiler.

The discharge piping should be supported so that loads (piping weights and dynamic forces during operation) transmitted to the relief valves are minimized. The weight supported by the valve should not exceed the weight of a short elbow and drip pan or comparable weight of a direct connected free hanging discharge pipe. Installations requiring long discharge piping runs should not have those discharge piping runs directly connected to the valve. The valve manufacturer should be consulted if the weight to be loaded on a valve outlet exceeds a short elbow with a drip pan.

7 BOILER START-UP

The design, manufacture, and assembly of your new unit is the result of years of engineering work and field testing. It is a sophisticated piece of equipment to be serviced only by qualified people. If you don't already have a qualified operator, we recommend that you contact your SBW representative for the name of experienced service personnel in your area.

Each burner can vary in details, but the following should help outline the steps involved with first time startup. The following section is provided as is, your burners manual will provide many details for safe first time start up.

WARNING

The improper installation, adjustment, service, maintenance, or operation of this equipment can result in fire, explosion, series injury, or death.

All Personnel involved with the startup, maintenance, or adjustment of this boiler must read and understand the entire contents of this manual prior to any startup or adjustment make to the boiler and related components.

Installation and service must be performed by a qualified installer, service agency or the fuel supplier.

7.1 Operating data

Whenever a new boiler is placed in service, operating data should be recorded, compared to predicted performance, and saved for future reference. This information is extremely valuable for diagnosing problems if abnormal operation occurs. Record all operating parameters such as pressures, temperatures, flows, draft losses, motor amps, turbine speeds, damper positions, and interlock set points.

This data assists operators to spot trends and take corrective action. Maintenance plans can be made by comparing the routine logs to the base data. For operating data to be meaningful, the instruments and controls must be well maintained and properly calibrated.

A new or relocated power boiler should not be put into operation until it has been inspected by an Authorized Inspector for the jurisdiction or insurance company and the required certificates have been issued.

7.2 Start-up guidelines

- Start-up and testing of new unit is a **SERIOUS** matter.
- Take time to become familiar with the equipment you will be working with.
- Review the burner manual.
- Review the wiring diagrams, operating sequence, piping schematics, installation drawings, and any other pertinent information for the particular pieces of equipment.
- Before applying electrical power to the unit, check all electrical connections to ensure they are secure and properly connected.
- Before applying fuel to the unit, check all piping to ensure it is arranged per the drawings and that all connections are tight.
- **DO NOT START THE BURNER UNLESS ALL CLEANOUT DOORS ARE SECURED IN PLACE.**

7.3 Tools & gages

Before you begin, check that the following tools & gauges are installed or available:

- Stack thermometer, typically 50-500°F
- Pressure (w/ Steam) or Temperature (w/ Water) gauge of appropriate range for you boiler.
- Flue gas analyzer
- U-tube inclined type manometer to measure stack draft and furnace pressure.
- U-tube or calibrated gauge for gas pressure.
- Multi meter.
- Meter to measure flame signal.
- A stack velocity meter, if you need to verify stack flow

7.4 Fuel guidelines

- Do not attempt to relight the pilot or start burner with the combustion chamber full of gas, or with very hot combustion chamber.
- Do not use gasoline, crankcase draining's, or any oil containing gasoline.
- **NEVER BURN GARBAGE OR PAPER IN THE UNIT, AND NEVER LEAVY COMBUSTIBLE MATERIAL AROUND IT.**
- Review all safety guidelines

7.5 Cleaning and filling a new boiler

Prior to starting a new boiler an inspection should be made to insure that no foreign matter such as tools, equipment, rags, etc., is left in the boiler.

Before putting water into a new boiler, make certain that the firing equipment is in operating condition to the extent that this is possible without actually lighting a fire in the empty boiler. This is necessary because raw water must be boiled [or heated to at least 180°F] promptly after it is introduced into the boiler in order to drive off the dissolved gases, which might otherwise corrode the boiler.

In a hot water heating system, the boiler and entire system (other than the expansion tank) must be full of water for satisfactory operation. The red, or fixed, hand on the combination altitude gage and thermometer is normally set to indicate the amount of pressure required to fill the system with cold water. Water should be added to the system until the black hand registers the same or more than the red hand. To insure that the system is full, water should come out of all air vents when opened.

7.6 Firing a new boiler

Commissioning and firing a new boiler is to be conducted by your installer. This process is beyond the scope of this manual. This is to be conducted by qualified personnel only. Refer to the burner manual for more information about starting up the burner.

NOTICE!

When tuning the flame in your new boiler, the flame should not be allowed to extend beyond the furnace. If the boiler is tuned with flame continuously past the furnace, this voids the warranty. Also see the boil out instructions and start up procedures for details on firing the boiler for the first time.

7.7 Boil-out procedure (1/2)

NOTICE!

All new boilers must be boiled out or Superior Boiler Works will void the warranty! Before introducing the boil-out chemicals to any drain system, check local environmental regulations to ensure you are in compliance

It is necessary to clean the inside of the new boiler of oil and grease used as tube rolling lubricants. Failure to remove these materials will result in your unit foaming, priming, and pulling over. These contaminants must be removed to provide clean heat transfer surfaces. Before boil-out procedures may begin, the burner must be ready for firing and the operator must be familiar with the procedure outlined under burner operation. SBT-710 is the chemical recommended for the cleaning of boilers. Dosage is one (1) gallon per fifty (50) gallons of water in the boiler. The operator must become familiar with the information in the SBT-710 technical data sheet and the MSDS.

1. Close valve in steam line (for steam boilers), Close off supply and return water valves (for water boilers), and Remove safety relief valves.
2. An overflow pipe should be attached to either the vent connection or a safety valve connection located at the top center of the boiler and routed to a safe point of discharge, in compliance with local environmental regulations. Use care in removing and reinstalling these valves. All other openings shall be closed off.
3. All valves in the piping leading to and from the boiler must be closed to prevent cleaning solution from getting into the system.
4. Fill Pressure vessel with soft water* to the normal water line. Add the SBT-710 and then fill to the top.
5. The boiler should then be fired intermittently at a low rate sufficient to hold the solution just at the boiling point. Maintain this temperature for a minimum of twelve (12) to twenty-four (24) hours to allow sufficient time for the removal of all dirt, oil and grease from the internal boiler surfaces. Do not produce steam pressure.
6. Add a small amount of fresh water to the boiler to create a slight overflow that will carry off surface impurities.
7. Maintain temperature and overflow until water clears of impurities. Do not produce steam pressure.
8. Shut down the burner, permit the boiler to cool to 120°F then drain boiler. Use caution that the hot water is discharged with safety.
9. Remove manway cover and hand hole plates, wash the waterside surfaces thoroughly using a high-pressure water system.
10. Inspect internal surfaces and repeat steps four (4) through nine (9) if necessary.

Note: Tubes near the sidewalls are usually the last to boil out because the temperature of the flue gas passing over them is lower.

7.7 Boil-out procedure (2/2)

11. All hand holes, manway, and any other openings shall be closed except a vent line. fill the boiler immediately to prevent flash corrosion. Fire boiler until water is heated to at least 180°F to drive off any dissolved gases that may corrode the metal.
12. On initial firing of the system, the condensate should be discarded until tests show the elimination of undesirable impurities. Proper Water Treatment must be maintained at all times to prevent scale and corrosion in the boiler and condensate return lines. See your water treatment professional for the program that best fits your needs.
13. Connect a vent pipe to the safety relief valve port on the boiler and run this vent to a drain.
14. Fire the boiler at a low rate for three (3) to four (4) hours allowing the steam to discharge through the vent pipe. (installed in place of the safety relief valve if necessary)
15. Drain the boiler while still warm. Remove manway cover, wash out hand holes. Wash interior of boiler with tap water at full pressure through a nozzle. Wash until all evidence of dirt, mud, and impurities are removed through the bottom hand hole opening. Clean any shell mounted probe holders.
16. When the boiler is so equipped, remove water level prove holder(s), and check for contamination that may have been caused by the boiler out chemicals. Clean the water side surfaces of the probe holder and the probe(s) to remove any contamination. Reinstall using appropriate pipe thread sealant to ensure a leak proof seal.
17. The boil-out procedure will be complete after replacing the safety valve and opening the outlet valve.
18. The above cleaning operation also serves to safely remove any moisture in the insulating refractory in your boiler.

7.8 Start-up of Steam boilers

If you know that the system is working safely, start up can be simplified to the following:

1. Review the burner manual for startup recommendations.
2. Set control switch in “OFF” position.
3. Make sure fresh air to boiler room is unobstructed.
4. Check availability of fuel.
5. Check water level in gage glass, make sure gage glass valves are open.
6. Use try cocks, if provided, to double check water level.
7. Vent combustion chamber to remove unburned gases. (integral to burner operation)
8. Clean glass on both the burner’s view port, and the boiler’s sight glass.
9. Set main steam shutoff valve in open position.
10. Open cold water supply valve to water feeder if provided. Open suction and discharge valves on vacuum or condensate pumps and set electrical switch for desired operation. Vent boiler to remove air when necessary.
11. Check set points of operating control, firing rate control, and high limit.
12. Check manual reset, if provided, on low-water fuel cutoff and high-limit pressure control to determine if they are properly set.
13. Set manual fuel supply valves in open position.
14. Place circuit breaker or fused disconnect switch in “ON” position.
15. Place all boiler emergency switches in “On” position.
16. Place boiler control start switch in “ON” or “Start” position. Do not stand in front of boiler access or cleanout doors. This is a precautionary measure should a combustion explosion occur.
17. Bring pressure and temperature up slowly, Stand by boiler until it reaches the established cut-out point to make sure the operating control shuts off the burner.

Notes: Once main flame has been established, visually check the flame and note its appearance. The flame should be relatively small to achieve a slow warm-up. The main issue is stable combustion and slow even heating of the boiler to minimize structural stresses.

NOTICE!

Failure to follow these instructions during initial firing voids warranty.

STEAM BOILERS SHALL BE TAKEN SLOWLY TOWARD HIGH FIRE AFTER THE SHELL TEMPERATURE HAS REACHED 220°F. The shell temperature can be checked with a magnetic thermometer either on the ASME Drum stamping or near a hand hole of the front of the boiler where the tubesheet is exposed. Some users wait until there is steam pressure in lieu of reaching a temperature to proceed.

18. During the pressure/temperature buildup period, walk around the boiler frequently to observe that all associated equipment and piping is functioning properly. Check for proper over the fire draft. **Note:** Remain fully aware of water temperature and flow rate or steam pressure and water level while operating the boiler at higher capacities.
19. Immediately after burner shuts off, inspect water column and open each try cock individually to determine true water level.
20. Enter into log book: Time and date of startup, any irregularities observed and corrective action taken. Time when control shut off burner at established pressure/temperature, tests performed, etc...
21. Check safety valve(s) for evidence of simmering. Perform try lever test. **See safety valve section under the operation section.**

8 OPERATION

8.1 Safety valves

Safety and safety relief valves are used to relieve excessive pressure generated within a boiler. The safety or safety relief valve (or valves) is the final line of protection against overpressure in the boiler. They discharge a volume of steam and/or hot water when relieving. This is the most important single safety device on any boiler.

Safety Valves. A safety valve is an automatic pressure relieving device actuated by the pressure generated within the boiler and characterized by full-opening pop action. It is used for steam service. Valves are of the spring-loaded pop type and are factory set and sealed.

8.1.1 Safety valves should be Try lever tested every 30 days of boiler service, after any period of inactivity, and before any pop tests are performed. A pop test is to be conducted once a year, preferably at the beginning of the heating season if the boiler is used only for space heating purposes.

All personnel concerned with conducting a safety valve tests should be briefed on the location of all shutdown controls in the event of an emergency, and there should be at least two people present. Care should be taken to protect those present from escaping steam. All safety and safety relief valves are to be documented including the date into your log book. Excessive hand lifting will shorten the life of the valve.

8.1.2 Safety valve tests (High pressure steam boilers)

Try Lever test:

The detailed step by step process is identical to low pressure boilers except that the pressures are different. With boiler pressure at least 75% of safety valve set point, fully open the safety valve for 5 to 10 seconds and let it snap shut. If the valve does not reseat properly, repeat the test. If the Safety/Relief valve cannot be lifted, the boiler must be shut down immediately until the valve can be repaired or replaced.

Pop Test:

Safety valves are to be pop tested once a year. The detailed step by step process is identical to low pressure boilers except that the pressures are different. The Pop pressure of the safety valve shall not exceed 3% of the MAWP. Also when multiple safety valves are installed, the complete range of pressure setting of all the safety valves on a boiler shall not exceed 10% of the highest pressure to which any valve is set.

8.1.3 Safety valve tests (Low pressure steam boilers)

Try Lever Test:

With the boiler under a minimum of 5 psi pressure, lift the try lever on the safety valve to the wide open position and allow steam to be discharged for 5 sec to 10 sec. Release the try lever and allow the spring to snap the disk to the closed position.

If the valve simmers, operate the try lever two or three times to allow the disk to seat properly. If the valve continues to simmer, it must be replaced or repaired by an authorized representative of the manufacturer. Inspect the valve for evidence of scale or encrustation within the body (without disassembly). Do not disassemble valve or attempt to adjust the spring setting. It is advisable to have a chain attached to the try lever of the valve to facilitate this test and allow it to be conducted in a safe manner from the floor.

Pop Test.

1. Establish necessary trial conditions at the particular location. Where necessary, provide adequately supported temporary piping from the valve discharge to a safe location outside the boiler room. In some installations temporary ventilation may dispose of the steam vapor satisfactorily. Review preparation for test with personnel involved. All such tests should have at least two people present.
2. Install temporary calibrated test pressure gage to check accuracy of boiler gage.
3. Isolate the boiler by shutting the stop valves in the steam supply and condensate return piping.
4. Temporarily place jumper leads across the appropriate terminals on the operating control to demonstrate the ability of the high-limit pressure control to function properly. After this has been checked, also place another set of jumper leads across the high-limit pressure control terminals to permit continuous operation of the burner.
5. The safety valve should pop open at an acceptable pressure, i.e., 15 psi \pm 2 psi. A simmering action will ordinarily be noticed shortly before the valve pops to the open position.
6. If the valve does not open in the 13 psi to 17 psi range, it should be replaced. It is not necessarily a dangerous situation if the valve opens below 13 psi, but it could indicate a weakening of the spring, improper setting of the spring, etc. If the valve does not open at 17 psi, shut off the burner and dissipate the steam to the system by slowly opening the supply valve.
7. If the valve pops open at an acceptable pressure, immediately remove the jumper leads from the high-limit pressure control. The burner main flame should cut off as soon as the jumper leads are removed.
8. The safety valve will stay open until the pressure drops sufficiently in the boiler to allow it to close, usually 2 psi to 4 psi below the opening pressure. This pressure drop (blow down) is usually indicated on the safety valve nameplate.
9. Relieve the higher pressure steam to the rest of the system by slowly opening the steam supply valve. After the boiler and supply piping pressures have become equalized, open the return valve.
10. Remove the jumper leads from the operating control and check to make certain that it functions properly. This is best done by allowing it to cycle the burner on and off at least once.
11. Enter the necessary test data into the boiler log book.

8.2 Gages

8.2.1 Pressure gages: A proper pressure gauge was shipped loose with your boiler and installation at a location indicated in the installation section of this manual. If your gauge needs to be replaced, the following information is helpful to specify its replacement. Pressure gages are used on both steam and hot water boilers. Gages can be damaged by overpressure or corrosion. **See Figures 11 & 12**

8.2.2 Gage siphon tube: On a steam boiler, a siphon tube (pigtail) is required to protect gages from steam. A valve is also provided to facilitate demand and servicing of the gage. SBW pressure manifolds are piped in a way that it works as a siphon loop. However, that siphon loop can be defeated by the user operating the inspectors gage cock. Because of this, some jurisdictions require pigtails on all of the devices including the pressure gauge that are mounted on the pressure manifold.

8.2.3 Pressure gage range: The gage range should be selected so that the gage will normally operate in the middle of the scale. For example, if the operating pressure is 50 psi, then a 100 psi gage should be used. For steam heating boilers, the gage should have a range of not less than 30 psi nor more than 60 psi.

8.2.4 Pressure gage accuracy: The gage accuracy is expressed in percent of full scale reading. For example, if a 100 psi gage is 2% accurate, then it will be within ± 2 psi of the actual pressure. A gage is usually more accurate at mid-scale and should be calibrated at that point. Most gages used on boilers have an accuracy of 1 % to 1 1/2%, an inspector gage is usually 1/2% accurate and a laboratory gage may have an accuracy of 1/4%.

8.2.5 Pressure gage calibration: The gage used on a boiler should be calibrated at least once per year. This can be accomplished by comparing it to an inspector gage or using a deadweight tester. If an inspector gage is used, the accuracy of that gage should be verified with a deadweight tester at least once every 2 years. If the gage is damaged or cannot be calibrated to provide consistent readings, it should be discarded and replaced with a new gage.

8.2.6 Stack thermometers

All boilers are supplied with a proper stack thermometer good for at least 500°F installed at a location indicated in the installation section of this manual. SBW stack outlets have two connections so that this may be visible for operators who work the boiler from either the right or left side.

8.3 Pressure controls

 WARNING
Overpressure can cause boiler explosion, serious injury, or death

Steam boilers are protected from overpressure by two pressure-operated controls; the high limit, and the operator. Shutoff valves of any type shall not be placed in the steam pressure connection between the boiler and the controls. These controls are protected with a siphon loop as a means of maintaining a

water seal that will prevent steam from entering the control. **See Figures 9, 10 & 13**

8.3.1 High limit: The high limit will cut off fuel supply when the pressure reaches the high limit set point. If the boiler's pressure reaches the high limit set point, a safety shutdown will occur that requires a manual reset. The manual reset button is on the controller its self to make the user aware of what has happened. On high pressure boiler's, the high limit set point shall not be higher than 90% of the safety valve's pop pressure. On low pressure boiler the set point needs to sufficiently above the operator to avoid nuisance tripping and below the safety valve's pop pressure. In the event the high limit scale includes pressures greater than the safety relief valve, a scale lock device is provided to prevent adjustment above it's appropriate value.

8.3.2 Operator: This control will cut off fuel supply when the pressure reaches an operating limit set point. This operator set point shall be less than the MAWP. For high pressure steam boilers, operator should nominally be set to 10% or 5 PSI less than the high limit to prevent nuisance tripping of the high limit.

When the pressure falls below the operator set point, the burner will continue to remain off until the differential interval of pressure has been passed that allows the burner to turn back on. This differential prevents cycling the burner too quickly. If the differentials set point (Operator-Operator differential) is set below the Modulators' set point, the burner will never be able to achieve low fire. This reduces the turn down ratio and efficiency of the system. This condition also causes more stress on the boilers internals.

8.3.3 Firing rate control: Unless burner is on/off, boilers are equipped with a modulating firing rate burner control. This control varies the firing rate of the burner between low to high fire depending on the load demand of your system.

For linked burners: the firing rate controls will be mounted on the pressure manifold like the high limit and operator. It will have two user adjustable controls. a modulator and a subtractive differential. The most common modulating control for linkage burners is a Honeywell L91B. When referring to its manual, the subtractive differential is referred to as a proportional band.

For linkage-less burners (Aka Parallel Positioning): The firing rate and an additional operator controls will typically be within the software of the burner. Refer to the software manual for details on its modulator control set points. Linkage-less burner also introduce the complication of an additional operator. A hardware operator like a Honeywell Pressuretrol or aquastats acts as a secondary safety without manual reset while the software operator actually performs the day to day of turning the burner on an off based on your application.

The modulator set point should be below the Operator differential. How much below is called the spread. The larger the spread, the larger the pressure range is that the boiler will spend in low fire. The modulator set point is the pressure at which the boiler will start ramping up from low fire to high fire. The modulator differential set point (Modulator set point-differential) is where the burner will achieve high fire. The larger the modulator differential, the larger is pressure range used for the burner to change from low fire to high fire.

With linkage-less controls on low pressure steam systems it can be a difficult balance of set points to

maximize the systems operation and minimize nuisance tripping of manual resets.

8.3.4 Pressure related settings will be in the following sequence from high to low.

- Safety valve pop pressure
- High limit
- Operator & subtractive differential
- Software operator & subtractive differential (on software controlled systems)
- Modulator & subtractive differential

8.4 Temperature controls

8.4.1 Low fire hold: Steam boiler may have low fire hold installed. Low fire hold prevents the burner from leaving low fire until its set point has been reached. This feature reduces the thermal stresses without user attendance during start up. **See Figure 26**

8.4.2 Minimum temperature: Any boiler may have this feature installed. Once the boiler is operating, this prevents the boiler from falling below the minimum temperature set point by turning on the burner at low fire. Once the minimum temperature is obtained, the burner is turned off.

8.5 Maintenance on pressure and temperature limiting controls

Maintenance on pressure and temperature limiting controls is generally limited to visual inspection of the device for evidence of wear, corrosion, etc. If the control is defective, replace it. Do not attempt to make field repairs. Also see the maintenance section for operational check of temperature and pressure limiting devices.

8.6 Example of control set point adjustment procedure

Given that the approximate desired plant operating steam pressure is known, review the factory fire test pressure control set points (shown on the Fire test Report) and make the appropriate adjustments on each set point. In the initial phase of adjustment, the original factory set spreads between set points should be maintained. Typical factory set points are stated below. For specific setting available on your set points, refer to the appended manuals for your burner or controls as appropriate. This information is presented as a procedure outline only. **See Figure Page 61**

Boiler Type	Limit	Operator	Modulator (Firing Rate)
Low Pressure	12#	10#	8#
150 PSIG MAWP	125#	100#	75#
200 PSIG MAWP	180#	170#	140#
250 PSIG MAWP	225#	215#	180#
300 PSIG MAWP	270#	260#	225#

Turning the larger main scale adjusting screw CW will raise the pressure, while CCW rotation will decrease it. The same convention also pertains to the smaller differential adjusting screw. The manual reset high limit control has no differential screw.

After the boiler has been started, the burner adjusted, and the safety devices checked out, the boiler should be put on line to carry a normal steam load. Note that control adjustment will be difficult to complete accurately if the load is either too high or too low. Control settings are determined by observing the steam pressure gauge at the point of switch function as opposed to relying on the pointer indication on the scale plate.

There is no benefit in adjusting the manual reset high limit and operating control set points too close to each other. This practice can lead to nuisance tripping and lockout of the high limit.

For high pressure boilers: A 10 PSI spread between high limit and operating control is practical. The manual reset high pressure limit should not be set any higher than ninety percent (90%) of the safety valve set pressure, while the automatic reset operating control **MUST NOT** be set any higher than ninety percent (90%) of the safety valve set pressure.

The minimum proportional band (Firing rate differential or modulator differential or throttling band) available on the 150 and 300 PSI Honeywell L91B modulating control is 5 and 12 PSI, respectively, while the maximum is 23 and 48 PSI. This means that the spread between operating control set point and modulating control set point must be greater than the proportional band in order to keep the burner in a continuous and modulated firing mode of operation.

The steam pressure control (operator) incorporates a subtractive control differential that will require a minimum decrease in steam pressure of 8 and 15 PSI, respectively, on the 150 and 300 PSI models before the burner can start. The arithmetic difference between the modulator throttling band and the pressure switch differential should be added to the throttling band in order to establish the proper spread between control and set points.

If the spread between the operating and modulating controls is too small, the burner will shut down on incremental load reduction before it reaches its minimum input at low fire. This mode of operation will cause wide steam pressure swings in the steam header and poor tracking of load changes. Fuel consumption will increase due to additional standby losses and increased cyclic pre- and post-purging of a hot boiler. Linkage and valve wear will increase due to a higher frequency of operation. Boiler life will also be shortened due to the stressing caused by alternate cold air purge and high fire burner operations, as well as thermal cycling of the vessel structure.

The spread between operating and modulating control set points should be maintained at the highest practical level (two to three times the actual modulating control proportional band). In most applications, it is reasonable to set the operating control differential and the modulating control proportional band near their respective minimums. If the burner firing rate constantly hunts up and down, the proportional band should be widened until the burner responds only to pressure changes visible on the pressure gauge.

The final check for proper pressure control adjustments should be to reduce boiler load to zero over a period of two (2) minutes. The burner will rapidly modulate to low fire and hold there until the operating control shuts it off. If the burner shuts off before it reaches low fire, further adjustments will be required.

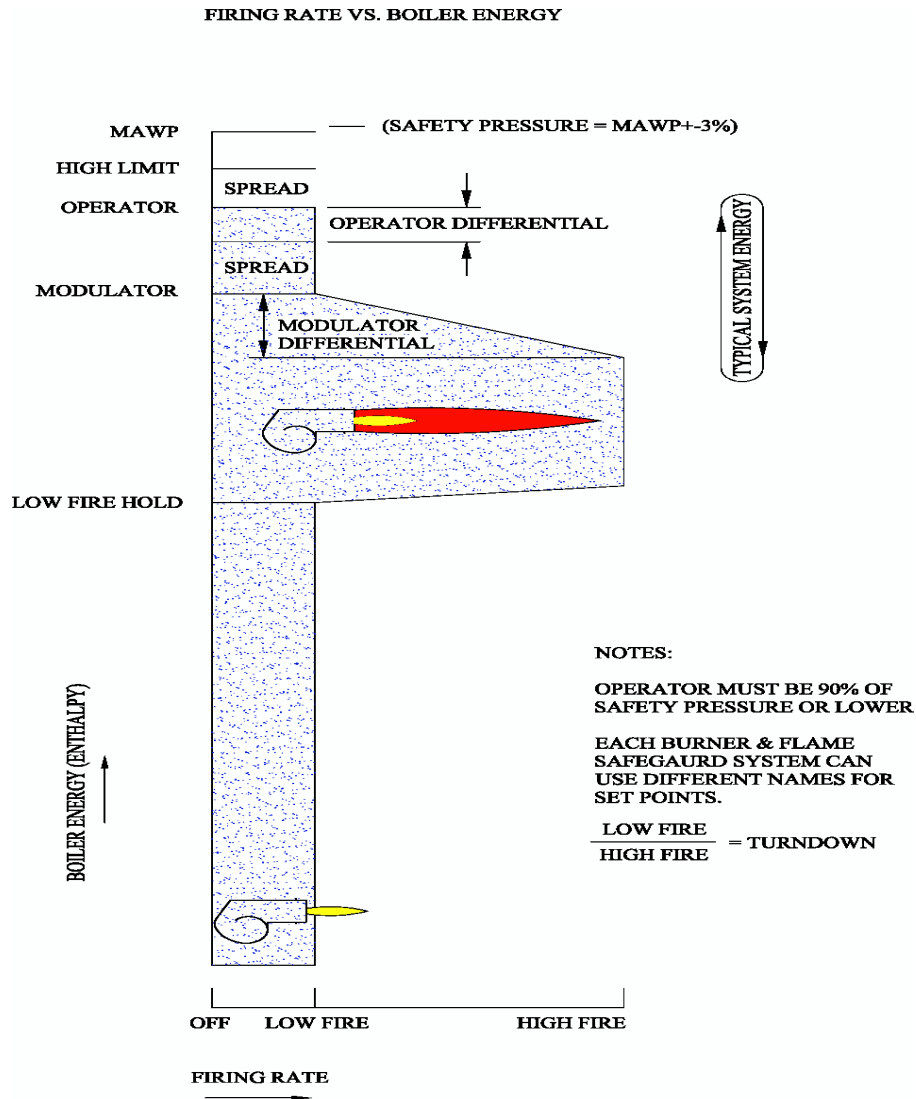

8.7 Water level controls

Water level controls are provided on every boiler. The most important function they provide is low-water fuel cutoff. Steam boiler water level controllers also control feedwater. Other water level controls like Auxiliary LWCO, and high water cutoffs are also provided depending on the specific type of boiler and configuration.

 WARNING
Low water level can cause boiler explosion, serious injury, or death.

Low-water fuel cutoffs are designed to provide protection against hazardous low-water conditions in boilers. History indicates that many boiler failures result from low-water conditions. Low-water fuel cutoffs may be generally divided into two types, float and probe. **See Figures 11,12 & 13**

8.7.1 Float type low-water fuel cutoffs

Float type low-water fuel cutoffs may be in combination with a water feeder or constructed as a separate unit. The combination feeder cutoff units are generally used on steam boilers while the cutoff units are sometimes installed on hot water boilers, or as a second cutoff on steam boilers. A feeder cutoff combination adds water as needed to maintain a safe minimum water level and stops the firing device if the water level falls to the lowest permissible level. Both operations are accomplished by the movement of the float which is linked to the water valve or pump control and burner cutoff switch. The units that serve as fuel cutoffs only are basically the same as the combination unit but without the water feeder valve. A water feeder installation normally acts as an operating device to maintain a predetermined safe water level in the boiler.

8.7.2 Electric probe type low-water fuel cutoffs

Electric probe type low-water fuel cutoffs may be contained in a water column mounted externally on the boiler or may be mounted on the boiler shell. Some consist of two electrodes (probes) that under normal conditions are immersed in the boiler water with a small current being conducted from one electrode to the other to energize a relay. Others use one probe and the boiler shell, in effect, becomes the other probe. If the water level drops sufficiently to uncover the probes, the current flow stops and the relay operates to shut off the burner.

8.7.3 Differential pressure sensor feedwater control

The third type of water level control used in SBW boilers is differential pressure sensor type. These operate by measuring the pressure from the top and the side of the boiler. When these two pressures are compared, the water level can be determined and used to control feedwater.

8.7.4 Low-water fuel cutoff and water feeder maintenance.

Low-water fuel cutoffs and water feeders should be dismantled annually, by qualified personnel, to the extent necessary to insure freedom from obstructions and proper functioning of the working parts. Inspect connecting lines to boiler for accumulation of mud, scale, etc., and clean as required. Examine all visible wiring for brittle or worn insulation and make sure electrical contacts are clean and that they function properly. Give special attention to solder joints on bellows and float when this type of control is used. Check float for evidence of flat ball collapse. Do not attempt to repair mechanisms in the field. Complete replacement mechanisms, including necessary gaskets and installation instructions are available from SBW. Test as required after re-assembly.

8.7.5 Water columns

Steam boilers come with at least one water column. Every right turn in a water column is attached with a fitting that facilitates cleaning. The steam connections to the water column(s) are taken from the top of the shell, and the water connection are taken from a point not above the center line of the shell. For every water column out of the top of a boiler, there are couplings on both sides of the boiler to facilitate re-plumbing to the other side if required. Periodically, all water columns should be blown down to prevent buildup of water contamination buildup and maintain trouble free operation.

A water column on a steam boiler contains the following devices: Primary float type LWCO, water gage glass and water column blowdown. The primary LWCO may also have tri-cocks, feedwater control, and a pushbutton shunt.

8.7.6 Primary LWCO: also see water level controls

Steam boilers have a float type primary LWCO. Periodically, the primary low-water cutoff should be tested under actual operating conditions. With the burner operating and the boiler steaming at normal water level, close all the valves in the feedwater and condensate return lines so the boiler will not receive any replacement water. Then carefully observe the waterline to determine where the cutoff switch stops the burner. If the burner does not shut off at the LWCO mark, the LWCO device should be serviced or replaced if necessary. The Primary LWCO should operate before the surface of the water falls below the lowest visible part of the water gage glass.

8.7.7 Pushbutton Shunt

A LWCO may also have a momentary push button shunt wired in the LWCO circuit that allows continuous boiler firing while blowing down the water column. When used, a LWCO indicator will still operate. If continuous firing is desired, the shunt button will need to be manually held until this indicator has switched off. The pushbutton shunt shall never be tampered with to allow operation without a person operating the button. This button will be located on the junction box.

8.7.8 Auxiliary LWCO

A steam boiler is equipped with a float or probe type auxiliary LWCO with a manual reset. In the event this device is activated to shut off the burner, the operator must reset the device. This will force the operator to become aware that the primary LWCO is not operating as designed. If your Aux. LWCO is a probe type, the reset button is located on the boilers junction box located near the water column mounted on the boiler. If the Aux LWCO if a float type, the reset button is located on the float device.

8.7.9 Water level manual reset

Manual reset for float type water level controls are located on the control. Probe type water level controls have the reset button located on either on the junction box or on the probe holder.

8.7.10 High water cutoff/alarm

A float or probe high water cutoff or alarm may be installed in steam boiler water columns or in the shell. This is used to prevent the volume of steaming space from becoming too small and to prevent water from entering the steam outlet. This is typically designed to operate 1" below the top of the gauge glass.

8.8 Water level operations

8.8.1 Gauge glass

Steam boilers have one or more water gage glass attached to the LWCO or water column by means of valve fittings not less than 1" NPS with the lower fitting provided with a drain valve of a type having an unrestricted drain opening not less than 1/4 in. in diameter to facilitate cleaning. Gage glass replacement is possible with the boiler under pressure. The lowest visible part of the water gage glass is at least 1 in. above the primary LWCO. **See Figure 8**

Check the water gage regularly.

The required frequency must be determined by trial. The check should be made when there is steam pressure on the boiler. Close the lower gage glass valve, then open the drain cock which is on the bottom of this valve, and blow the glass clear. Close the drain cock and open lower gage glass valve. Water should return to the gage glass immediately. If water return is sluggish, leave the lower gage glass open and close the upper gage glass valve. Then open the drain cock and allow water to flow until it runs clear. Close the drain valve and repeat the first test described, with the lower gage glass valve closed. If leaks appear around the water gage glass or fittings, correct the leaks at once. Steam leaks may result in a false waterline and they also may damage the fittings.

If water disappears from the water gage glass, blow down gage glass (described in previous paragraph) then water column to see if water appears. If it does not appear, then stop the fuel supply immediately. *Do not* turn on the water feed line. *Do not* open the safety valve. See next page for more on maintaining water level.

Appearance of rust

If rust appears in the water gage glass, this is an indication of corrosion that must not be ignored. Check the boiler water to be sure that the water treatment compound is at proper strength and make sure the boiler is not requiring considerable quantities of makeup water. Check the return line and other parts of the system for evidence of corrosion.

Waterline fluctuation

A wide fluctuation of waterline may indicate that the boiler is foaming or priming. This may be due to the water level in the boiler being carried too high, or, especially in low-pressure boilers, a very high rate of steaming. Foaming may also be caused by dirt or oil in the boiler water. Foaming can sometimes be cured by blowing the boiler down, draining 2" or 3" then refilling a few times. In persistent cases, it may be necessary to take the boiler out of service, drain, and wash out thoroughly as described in the boil-out procedure, then refill, and put back into service.

8.8.2 Try-cocks

Your steam boiler has a set of three cock's located on the primary LWCO. These are used to confirm gauge glass water level reading. The bottom cock should vent water. The top cock should vent steam, the middle cock should vent a mixture of water and steam. If they do, you have confirmed proper water level in the boiler.



Escaping water and steam can cause burns.

8.8.3 Steam boiler Feedwater:

Your steam boiler's feedwater inlet is equipped with a manual stop valve and check valve to prevent back flow from the boiler into your feedwater system. The feedwater system can be isolated from the boiler under pressure by closing the stop valve.

Your steam boiler is equipped with either on/off or modulating feedwater controls. This automatic control system can either be part of the primary LWCO or a separate set of water level controls. The automatic feedwater valves shall be field plumbed by the installer in a way that it can be bypassed and manually operated. SBW offers a three valve bypass including a manual metering valve to aid in accomplishing this. When water makeup is needed and neither the boiler nor the condensate tank is equipped with an automatic water feeder, manually add water to the steam boiler. **See Figure 8**

8.8.4 Maintaining Proper Water Level

Every effort should be made to place feedwater control on automatic operation as soon as possible during startup because they require constant operator attention otherwise. **Operating without sufficient water to cool pressure parts is the most common way to destroy a boiler.** Maintenance of water at a safe level in the boiler is of vital importance. It must not be allowed to go low enough to endanger the boiler through overheating or to go high enough to interfere with correct functioning of steam and water separation devices. Automatic level control devices and low and high level alarms should be considered solely as operating aids and should not be relied upon entirely. Water level, as indicated by two or more devices, should be frequently compared. Significant (more than 1/2") differences in level indications should be promptly investigated and reconciled. The water level in a steam boiler shall be maintained so that it is under 1" above the bottom of the gage glass, and under 1" of the top of the gage glass.

If the water level is not visible in the gage glass, shut off the burner but continue to feed water slowly until the normal water level is restored. See the previous page about the gage glass. Also, the tri-cocks can be used to confirm the water level in the gage glass. Other indications of low water conditions include higher than normal water or stack temperature. Operation of the unit can be maintained provided immediate action is taken to restore the water level to normal level. This should be done with care, using all indicators available, such as feedwater flow meter, steam flow meter, gage glass, try-cocks and all other instruments that properly sense the operating conditions of the boiler.

The best, safest advice is: **IF IN DOUBT - SHUT DOWN THE BURNER, CONTINUE TO FILL WITH WATER UNTILL NORMAL WATER LEVEL IS OBTAINED.** Note: water boilers don't have a normal water level, they are flooded systems.

If a complete shutdown occurred, let the boiler cool until the exposed drum is at hand touch temperature. Then add water to obtain at least 1" of water in the gage glass. *Do not* put the boiler back into service until the condition responsible for the low water has been identified and corrected.

8.8.5 High or low water level

In the case of either low or high water, the underlying cause should be determined and the appropriate Corrective action taken before attempting to resume normal operation. The water level should be controlled manually until the automatic control is known to be functioning correctly and normally.

8.8.6 High Water Level.

If the water level is above the visible range of the gage glass, shut off the feedwater, fuel, and combustion air in that order. If water level does not recede into the visible range of gage glass within 2 min, operate main blowdown valves as required to lower the water level.

8.8.7 Abnormal Water Losses.

Where water losses from a steam boiler become abnormal, as indicated by the requirement of large amounts of manually fed makeup, an investigation should be made immediately to determine the cause. Boilers operated with automatic water feeders requiring an increase in water treatment should be investigated immediately for cause of loss of water. Proper repair or replacement of parts should be made at once rather than to increase the water treatment to protect the system due to excessive raw water makeup. If the operator cannot determine the cause of the water loss, a competent contractor should be contacted.

8.8.8 In case of low water

If there is any possibility that the boiler has been damaged, it should be cooled down and thoroughly inspected for damage due to overheating.

8.8.9 Water Carryover.

Steam boilers come installed with either a dry pan or a dry plate. This should be supply better than 99% quality steam. If you do discover water carryover, high water level, or improper water treatment are more than likely the cause. Foaming may be caused by a high concentration of dissolved solids and suspended matter in the boiler water. Blowing down and feeding fresh feedwater should be effective in reducing the boiler water concentration and thereby stopping the foaming, if this is the cause. Contaminants in the feedwater can also cause foaming regardless of the boiler water concentration and antifoaming agents can be introduced to aid in reducing the foaming tendency.

8.9 Water Treatment

Water treatment starts with the boil out procedure and the quality of your feedwater. Boiler feed water, regardless of the type of treatment program used, will still contains measurable concentrations of impurities. To maintain reliable boiler operation the concentrations of each component of the boiler's water must be limited to certain maximums. Feedwater treatment, chemicals, and blowdown are the typical means used to maintain water quality inside your boiler.

One component of this is accomplished by blowing down water from the boiler. Maximum trouble free boiler life is in most cases tied directly to proper boiler water treatment. The exact chemistry of water varies so much from one area to another; there is no such thing as one treatment being effective in all areas. Treatment must be provided to prevent scale formation, oxygen corrosion, excess acidity, control of total dissolved solids, prevent caustic embrittlement, and so forth. We, therefore, recommend that you contact a reputable boiler treatment company operating in your area for advice in this field.

If the quality of your feedwater is known, the following limits can help you make initial estimates of your blowdown frequency

Water inside your boiler

Boiler PSIG	Tot. Dissolved solids ppm	Tot. Alkalinity ppm as CaCo3	Suspended Solids ppm	Silica Ppm *	Total Iron (FE) ppm
0-250	3500-5000	1200-900	100	100-150	10
250-350	3000-4000	900-700	25	100-120	8

Feedwater Limits

Drum Pressure PSIG	Dissolved Oxygen ppm	Total Iron ppm	Total Copper ppm	Total hardness ppm	pH	Nonvolatile TOC ppm	Oily Matter ppm
0-15	<0.03	≤ 0.1	≤ 0.05	≤ 1.0	8.3...10.5	<10	<1
16-300	<0.007	≤ 0.1	≤ 0.05	≤ 1.0	8.3...10.5	<10	<1

8.9.1 Heating boilers

Water treatment in a heating boiler is usually not a problem because the same water is used over and over. Treatment is primarily to eliminate corrosion and pitting cause by alkalinity and oxygen. It is usually necessary to treat the water in a heating boiler once a year at the beginning of the heating season. SBW recommends you consult a competent water consultant to determine your water treatment. The appearance of scale, corrosion or pitting is definite evidence that water treatment is needed.

8.9.2 Process steam boilers

When the boiler supplies steam for processing, it is necessary to replace steam used with makeup water. Water treatment for boilers supplying process steam varies with analysis of water available. It is, therefore, strongly recommended that the owner secure the services of a competent water consultant to run water analysis and recommend a treatment.

8.9.3 Water treatment guidelines

Get professional help

Detailed instructions for feedwater treatment should be prepared by a competent feedwater chemist should be followed. It is inadvisable to experiment with "homemade" treating methods or compounds. Representative samples of feedwater and boiler water need to be analyzed frequently to ensure they are within specifications.

Oil & water don't mix

Every effort should be made to prevent oil from getting into the water side of boilers. Oil causes foaming or combines with suspended matter to form a sludge that, in turn, can cause overheating of pressure parts through its insulating effect. Oil gets into boilers usually in the form of contaminated condensate from fuel oil heaters or from leaking valves in lines providing steam to the oil burner system. It is, therefore, important to continuously monitor the quality of condensate returned and discard it whenever contamination is detected. If oil does get into a boiler, the boiler should be taken out of service immediately and thoroughly cleaned.

Heating boilers should not breathe

Use every practical means for excluding oxygen from a boiler's water. One source of oxygen is makeup water; therefore, hold makeup to a minimum. If a water boiler in a closed loop system loses more than 3 in. of water per month, this indicates there probably is a leak in some part of the system. The leak should be found and corrected.

The system should breathe

If the system includes a pump for returning condensate or adding feedwater, be certain that the air vent at the receiver is operating properly.

Deaerator & Feedwater tanks

If large quantities of feedwater are required, deaerating equipment is recommended to remove dissolved gases, thereby reducing oxygen corrosion.

8.10 Boiler blowdown

8.10.1 Boiler blowdown calculations

Proper boiler blowdown procedures are an essential part of fire tube boiler operation. It is necessary to control the amount of total dissolved solids in the boiler water. The total dissolved solids should not exceed 3500 parts per million in a scotch marine boiler. If boiler blowdown is not controlled, excessive dissolved solids will have tendency to increase and concentrate to a point that will cause a foaming or a carryover condition contaminating the steam. High concentrations of total dissolved solids in fire tube boilers have a tendency to collect as scale on the heat transfer surfaces. Scale is an excellent insulator and it's collection on the heat transfer surfaces of a boiler significantly decrease the heat transfer characteristics. This results in overheating the boiler tubes and tubesheets which in turn will result in tube leakage.

Boiler blowdown can be accomplished either manually or automatically. Manual blowdown involves the operating personnel opening the boiler blowdown valves for a predetermined length of time at regular intervals. Automatic blowdown can be accomplished by many methods. The most common automated method is the use of a surface blowdown skimmer attached to a calibrated blowdown valve which permits a continuous preset amount of boiler water to be blown down.

The proper blowdown rate can be determined from the flow rate and total dissolved solids measurement of the feedwater. The amount of total dissolved solids in the feedwater can be determined from a water analysis. The amount of feedwater water being used is normally determined with the use of a water meter installed in the make-up feedwater line. The correct amount of boiler blowdown as a percentage of feedwater can be calculated with the following formula.

$$\text{Percentage of boiler blowdown} = \frac{\text{Total dissolved solids in the feedwater}}{3500 - \text{total dissolved solids in the feedwater}} \times 100$$

Example, assuming feedwater contain 200 part per million of total dissolved solids (TDS)

$$\frac{200}{3500 - 200} \times 100 = 6\% \text{ of make up}$$

The proper boiler blowdown rate can be calculated when the amount and total dissolved solids of the feedwater are known. Once you have that percentage, with a known flow rate of feedwater, the duration and frequency of blowdown can be determined.

8.10.2 Blowdown procedures

Boilers are equipped with bottom blowdown connection(s) and valves. Bottom blowdown is used to lower total dissolved solids, limit sludge buildup, and adjust boiler chemistry. Optionally they are equipped with a surface blowdown system. The surface blowdown system is equipped with either a dip tube or surface skimmer. Optionally the surface blowdown system can be tied into an automatic surface blowdown system. Surface blowdowns are conducted to remove surface film, oil, etc. Exact blowdown requirements and procedures need to be determined with your water professional and for your specific application.

8.10.3 Process boilers

It is important that the concentration of solids in the water be determined at least daily, and the blowdown (continuous or intermittent) should be regulated to control the concentration within the prescribed limits of your water quality professional. A safe maximum water concentration of solids in boilers can best be maintained by adjusting the blowdown frequently on the basis of water analysis. If the boiler is not fitted with sampling connections, the boiler should be blown down at least once every 24 hr.

8.10.4 Heating boilers

Where boilers are used solely for heating and where practically all of the condensate is returned to the boiler, blow down only as often as concentration of solids require. The recommended boiler blowdown with a leak free heating system is the withdrawal of one gallon/200 BoHP of water monthly from the boiler. In heating systems which require the addition of water to the boiler frequently, it is good practice to blow the boiler down more frequently.

8.10.5 Bottom blowdown valve operation.

Bottom blowdown is normally conducted by fully opening the fast acting valve first, then opening and closing the slow acting valve. When finished with blowdown, open and close the slow acting valve again to relieve pressure between the blowdown valves.

When a large amount of blowing down is necessary, open the quick opening valve first until it is half open and leave it in that position; open slow opening valve until water is lowered about 1/2 in. in the gage glass; then open both valves wide until blowing down is completed. See that the valves shut off tight and remain tight. Leaking blow off valves should be repaired at the first opportunity.

During blowdown, unless the operator can clearly see the steam drum gage glass, an assistant should be stationed to watch the gage and positioned to signal the operator. Never permit an operator at the blow off valve to leave until blowdown operation is completed and blowdown valves are closed. No other duty should be performed during blowdown. If you are performing blowdown with the boiler in service, schedule blow off at reduced or moderate rates of steaming. If you have a multiple boiler installation, only one boiler should be blown down at a time. **The operator must ensure that all persons are clear of the blowdown piping escape point.**

8.11 Access openings and burner mount

8.11.1 Hand holes and Manway

These openings are placed in the boiler to facilitate visual inspection, cleaning and maintenance. Upon evidence of leakage, the plate should be tightened by tightening the nut(s) holding it in place. It is not uncommon for a new unit or a newly gasketed plate to start seeping after being in use a short time due to the gasket softening a bit upon exposure to moisture and heat. This seepage can be stopped as pointed out above. It is good practice to always use new gaskets on these plates after they have been removed. Be sure there are no foreign particles on the seating surface of the plate or boiler before installing new gaskets. Do not tighten nuts with pressure on the boiler, when the boiler cools down, the tension on the bolts will increase. Gaskets are available from SBW. At least one set of gaskets should always be on hand.

See Figures: 25

8.11.2 Smokebox Doors

Smoke box doors supported by davit arms. The sealing of the smokebox doors is accomplished with angled lugs around its periphery. Even tension of the lugs is important to prevent leakage. Every time the smokebox doors are opened, the gaskets around the periphery should be changed out. Gasket kits are available from SBW. At least one set of gaskets should always be on hand.

See Figures: 14

8.11.3 Cleanout Plug

A cleanout plug is provided on the rear of the boiler that allows access to the furnace without opening the rear door. The cleanout plug also contains a sight glass to facilitate viewing of the furnace flame for adjustments. The sight glass may come with a manifold that allows for air cooling of the sight glass and/or measurement of the furnace pressure. Spare sight glass and gaskets are available from SBW. At least one set should set should always be on hand.

See Figures: 15, 16

8.11.4 Burner mount

A burner mount has been custom made to match with your burner. No maintenance other than replacement after seven years should be required. When replacing, the details are in the related figures.

See Figures: 17, 18, 19, 20

8.11.5 Refractory

Refractory is part of the cleanout plug, burner mount, rear door, bridging, and block. The refractory typically has a life of about seven (7) years. SBW recommends that you order one of each once you see any spauling of refractory. After ten (10) years, even if the refractory looks good, it should be replaced. By this point in time it will have become very brittle and can completely break apart unexpectedly.

9 MAINTENANCE

With proper operation and maintenance you can expect years of trouble-free service from your new boiler. The next few pages give guidelines for typical boiler maintenance. Cover plates, enclosures, and guards shall be maintained in place except during maintenance.

Periodically, the waterside surfaces of the boiler should be visually checked for scale formation, pitting, and corrosion. Scale collection should not be thicker than an eggshell, as scale is a good insulator and can considerably lower your boiler's overall efficiency. When lowering the water level or draining the boiler for inspection, caution must be used. **DO NOT DRAIN A HOT BOILER QUICKLY.** Good practice would dictate draining the boiler only after it has been out of service at least twenty-four (24) hours.

Notice!

IN NO CASE EVER FILL A WARM BOILER WITH COLD WATER. THIS WILL CAUSE TUBE LEAKAGE. If you want to reduce the time it takes to cool off the boiler, the burners fan can run cool air through the boiler. This is not a recommended practice, however in some cases the downtime cannot be afforded to allow the boiler to cool down slowly.

9.1 Spare Parts.

Spare parts for controls, including electronic components which require time for procurement, should be maintained in stock supply. Spare part should be kept in the boiler room or close by in a cool dry place.

In case you need to open up your boiler unexpectedly, it is a good idea to keep spare gaskets on hand. The sight glass, sight port, and water gage glass are made of glass. It is recommended that you keep spares on hand.

Many locations require that boilers are inspected once a year. Typically the yearly maintenance is conducted at the same time as this inspection. A full set of gaskets will be needed to reseal all of the access openings.

Documenting the start up is required to activate your warrantee. Keeping records of all boiler activities can be helpful in troubleshooting if you have a problem with operations.

9.2 Maintenance schedule

The suggested maintenance schedule has been broken down into daily, weekly, monthly, semiannual, and annual procedures. The exact frequency of your inspections may vary. The schedule presented here is a good place to start. Over time you can determine exactly how often each items needs to be checked. Examples of maintenance logs are provided, however, the end user is responsible to create log sheets that match with the specifics of your system.

A permanent log book should be provided in each boiler room to record maintenance work, inspection, certain tests, and other pertinent data. Brief details of repairs or other work done on a boiler plant (including time started, time completed, and signature of person in charge) should be recorded. Performance and results of test, inspections, or other routines required by codes or laws, insurance company inspection reports, and initial acceptance test data should be recorded.

A double asterisk (**) is used to indicate that your boiler manual should also be checked for information on the topic being covered.

9.2.1 Daily procedure (also see the burner manual's procedures)

1. Blow primary LWCO down while burner is firing. Verify that feedwater pump cycles normally and that burner shuts off. All blowdowns should be opened slowly. Quickly opening the water column blowdown can collapse the float ball.
2. Check function of auxiliary LWCO while burner is firing; verify proper response of alarms and that it shuts the burner off.
3. All water level controls should be tested for proper operation.
4. All gauges, monitors, and indicators should be checked for proper operation.
5. Observe burner starting sequence and flame characteristics to verify normal behavior. Check furnace for debris and sooting, also inspect refractory through flame.
6. If an operating log is kept, enter reading; otherwise, conduct visual check of all pressure and temperature gauge readings.
7. Check safety valves, hand holes and manway for signs of leakage.
8. If the boiler is firing oil, check level in oil storage tank. If the burner has an atomizing air compressor, check its lubricating oil level.
9. Check stack temperature. If temperature is higher than normal, check burner operation for over-firing or improper combustion.
10. Check temperature of water supplied to unit and if below 140 °F preheat return to about 165 °F.
11. Check water sample readings for proper chemical treatment.
12. Perform bottom blowdown at an interval set by your water treatment professional.

9.2.2 Weekly procedure (also reference the burner manual's procedures)

1. Check the pressure limit shutdown. During this check, observe the operation of the primary safety to make sure that the operation is as described in the sequence of operation section of the burner manual.
2. Wipe the entire unit, particularly the operating parts, so that oil and dust do not accumulate.
3. Check combustion control operation as outlined in check list section of burner manual. Investigate and correct any failure at once. **
4. Check flame safety control's response to lack of flame with main gas off. **
 - Intermittent Pilot – Start burner with pilot gas off, verify lockout.
 - Interrupted Pilot – Start burner with pilot gas on, verify lockout.
 - Determine that alarms are reacting to lockout.
7. Details about your lockout system timing should be provided with the burner manual. **
8. During and after flame failure test, observe ignition spark and pilot flame for abnormalities. **
9. Record pilot and main flame signals if proper meter is available. **
10. Verify that main fuel valves are closing within specified timings; check valve position indicators. **
11. If boiler is equipped with modulating burner, verify that adequate differential exists between operating and modulating controls to prevent short cycling. **
12. If you have chemicals being introduced directly into the boiler, check chemical feed equipment against the check list supplied by your water treatment professional.

9.2.3 Monthly procedure (also reference the burner manual's procedures)

1. Clean feedwater strainer between the pump and the condensate return tank.
2. Clean the air intake filter on the atomizing air, if air compressor is present. Replace filter oil with clean compressor lubricating oil.
3. Clean combustion air fan and air inlet assembly.
4. Check rear door for flue gas leaks and tighten bolts as required. Tighten bolts evenly - uneven tightening could cause leakage.
5. Manually blow boiler safety valves.
6. Clean scanner lens.
7. Test low draft, combustion fan air flow switches mechanically and electrically. Sail switches can remain stuck in closed position if shaft is dirty. Disconnect wire, start burner, verify that pilot does not light. Reconnect wire when finished.
8. Check low fire hold, proving switch circuit mechanically and electrically. Terminal must not be powered until motor returns to low fire position. If wire is disconnected, verify that pilot does not light. Reconnect wire when finished.
9. Check "open damper proving switch circuit" mechanically and electrically. Terminal must not be powered until motor reaches high fire position. If wire is disconnected, verify that motor remains at high position. Reconnect wire when finished.
10. Test main gas valves for leakage. Close checking cock, connect hoses to open leak test valves, submerge hose ends in water, and watch for bubbling.
11. Test fuel pressure interlock switches. With burner in normal operation (preferably at high fire), raise low gas or oil pressure switch set point above available fuel pressure. Burner must shut off when visual indicator trips. Test high gas pressure switch by reducing set point below existing manifold pressure. Again, burner must shut off when indicator trips. After returning to normal set points, burner must not restart until switches have been manually reset.
12. Test oil atomizing medium interlock by interrupting flow of compressed air or steam to burner. Oil valves must close, with subsequent flame safeguard lockout.
13. Manually lift safety valve with test lever momentarily while boiler is at normal operating pressure. You should see flow out of this valve. If the valve does not flow when opened, or properly close afterwards, refer to the safety relieve valves manual for further details.
14. Check the Flue gas connector, vent connector (breaching), and stack for leaking and or corrosion. All vent system components and draft controls shall be checked per their manuals or instructions provided by the installer.
15. Test high and low oil pressure and oil temperature interlocks. Refer to the burner manual for details.

9.2.4 Semi-Annual procedure (Also reference the burner manual's procedures)

1. Cool boiler slowly to room temperature. (110°F minimum) NOTE: Failure to cool boiler slowly can cause tubes to leaks. This is very important! To assist cool down, use the Test/Run or Check/Run switch located on the programmer to run the blower.
2. Remove all the nuts and clamps around the front door flange, pry the door loose from the boiler and swing it away on the davits.
3. Using the flue brush and vacuum cleaner, brush through the tubes to the rear end of the boiler.
4. Soot and scale may be removed from the rear end of the boiler by removing the cleanout plug located at the bottom of the rear door and inserting vacuum cleaner hose. (Does not require large door to be open) Check the refractory on the clean out plug for spalled areas.
5. Always replace the 1" ceramic fiber seal around the edge of the rear refractory with a new seal when rear door is opened and gasket is damaged.
6. Tighten front and rear door nuts evenly to take up any slack created through drying out.
7. Clean the sight port glass, replace if required.
8. Flush air compressor as directed in its manual and or in the burner's manual. **
9. If boiler is used for a steam process with a high percentage of feedwater makeup, follow the Annual Procedure Items 2 & 3.
10. Clean & Adjust pilot Assy. This will be covered in the burner manual. **
11. Re-calibrate all indicating and recording devices
12. For steam boilers, perform a slow drain test of the low water fuel cutoff device.
13. Check flame failure detection system components. Refer to the burner manual for additional instructions.
14. Check firing rate control. **
15. Check piping and wiring of all interlocks and shut off valves. **
16. Inspect burner components, refer to the burner manual for additional instructions. **
17. Since the LWCO wiring terminal strips tend to be at the highest operating temperatures found in the boiler control circuit, check wire insulation for brittleness, cracking, or missing patches.
18. Disassemble and clean all safety control related piping – LWCO equalizers, pressure control manifolds, and air flow switch tubes.
19. Check boiler pressure gauge against calibrated master gauge or with dead weight tester. New gauges are built to one percent (1%) accuracy.

9.2.5 Annual procedure (also reference the burner manual's procedures)

1. Follow steps 1 through 10 listed under Semi-Annual Procedure.
2. Clean water side of boiler as follows:
 - Open upper tri-cocks and any other available vent valves to prove that the boiler contains no steam.
 - Drain the boiler through the blow down valve. Start washing down tubes ASAP.
 - Wash down the inside (water side) of the boiler with a hose, making sure to get all sludge and scale out of bottom of boiler.
 - Remove all hand hole covers and the manhole cover.
 - Inspect shell and tube surfaces for signs of corrosion or scale formation. If scale is forming (to any degree) on internal surfaces, chemical treatment is not correct. Consult your water treatment professional.
 - Remove plugs from low water cutoff equalizer crosses and rod piping if scale is present. Remove low water cutoff head and clean float chamber. Reassemble with new gasket.
 - Using new gaskets, install the hand hole covers and manhole cover.
 - Disconnect the piping on the discharge side of the feedwater pump and inspect for scale build up. Check stop and check valves for proper operation and replace if necessary.
 - Test the safety relief valves. If the safety relief valves fail to properly operate, they shall be replaced with new safety valves of proper pressure and capacity rating. Old valves may be refurbished by a reputable valve repair company with a VR stamp and kept as spares.
 - Fill the boiler by means of the feedwater pump and reset the low water cutoff.
3. At the time of this yearly inspection and cleaning, it is recommended that the local State or insurance inspector, in addition to the SBW distributor, or agent, be called in to check the condition of the equipment. Water treatment professional should also be present.
4. Jumper operating control and run boiler under manual control at reduced load to determine if high limit control functions correctly. Remove jumper wire when finished.
5. Bypass both operating and high limit controls under manually controlled low load condition. Gradually bring boiler pressure up to safety relief valve set point. 15# valves must open at 15#. Valves rated 15 to 69# are permitted two percent (2%) tolerance, and 70 to 300# valves may vary by three percent (3%).
6. Remove gas line strainer basket and clean.

Annual procedure (Continued), (also reference the burner manual's procedures)**

10. Flame failure detection system, pilot turn down test. **
11. Infra red refractory hold in test. **
12. Check dual fuel change over control. **
13. Replace scanners or flame rods in accordance with manufacturer's instructions. **
14. Conduct a combustion test. **
15. Check all coils and diaphragms; test other operating part of all safety shutoff and control valves. **
16. Test fuel valve interlock switch in accordance with manufacturer's instructions. **
17. Perform leakage test on pilot and main gas and/or oil fuel valves. **
18. Test purge air switch in accordance with manufacturer's instructions. **
19. Test air/steam interlock in accordance with manufacturer's instructions. **
20. Test low fire start interlock in accordance with manufacturer's instructions. **
21. As required. **
 - Recondition or replace lower water fuel cutoff device
 - For oil-fired burners, clean atomizers and oil strainers.
 - For gas-fired burners, check drip log and gas strainers.
 - Flame failure detection system, pilot turn down test.
 - Flame failure detection system, test for hot refractory hold in.
 - Test safety valves in accordance with SRV tests.

9.3 Detailed Empty inspection

Before commissioning, and as required the boiler can be drained and inspected in detail. The following checklist is what most inspectors will be looking for.

Safety Checklist for Inspection

1. Before entering any boiler, lock out and tag all equipment items with movable parts connected to the boiler and fuel system and place a sign at the operating controls indicating that a workman is in the boiler.
2. Before entering any power boiler, make sure it is properly isolated at ALL fuel, flue gas, steam and water sources; make sure it is properly vented and obtain an air sample to check for breathing quality. Use low voltage lights or explosion proof flashlights inside the boiler.
3. Notify the person in charge at the site when beginning and upon completion of the inspection.
4. Inspect with another person so if assistance is required help will be close at hand.
5. Always be aware of the nearest escape routes.
6. Before closing drum manholes and furnace doors, it is essential to ensure that all personnel are out of the boiler.

Water Side Checklist

1. The water side, including drums, tubes, and furnace should be free of extraneous material such as dirt, tools, rags, wood, or trash.
2. All internal fittings should be in serviceable condition and securely installed in the correct position.
3. Look for evidence of corrosion on pressure parts.
4. Look for erosion at mating surfaces of man ways, hand hole caps, and flanges
5. Note location and type of deposits in boilers that have previously been in operation and collect samples for analysis.

Fire Side Checklist

1. All combustion air and flue gas passages such as the furnace, smokebox, ductwork, and fans should be free of extraneous material.
2. It is especially important to remove all combustible material that might ignite, burn, and trigger the explosion of unburned fuel if ignition is lost or interrupted at the burners.
3. Dampers and burner registers should be operated to confirm that they are free to travel from fully closed to wide open. (Canadian boiler vent damper may have a stop preventing full closure)
4. Check to verify that the refractory is correctly located and properly installed. Burner orifices, over-fire air nozzles, observation ports, and instrument taps must not be covered or plugged. Repairs should be made if refractory is missing or significantly damaged. Slag should not be removed from the surface of the refractory unless it interferes with normal operation. It is very likely that chunks of refractory will be removed with the slag.
5. Turn off the light occasionally while inside the unit and look about for daylight shining through holes that indicate air or flue gas leaks.
6. Always carry a note pad and pencil and make notes of conditions found to avoid reliance on memory. Sometimes a photograph or sketch will be valuable as a reference base for future inspections.

Look for corrosion of pressure parts:

1. under deposits;
2. at tube-to-tubesheet joints;
3. where the flue gas may have been below its dew point;
4. under refractory or insulation if it has been water soaked for a period of time.

Look for erosion:

1. of draft fan housings and wheels handling dirty gas
2. in the vicinity of soot blowers
3. at sharp turns or points where dirty gas flow may concentrate
4. in areas near where any steam or water leaks have occurred

Look for overheating:

1. of tubes in the areas of high heat application, especially if there is evidence of deposits inside the tubes. Often minor swelling of tubes is easier to feel than it is to see. A flashlight beam may be used to detect blistering.
2. at the top end of tubes in boilers that may have experienced operation at low water level;
3. whenever tubes are warped or otherwise physically distorted. A flashlight beam parallel to the furnace wall highlights out-of-plane tubes.

External Checklist:

1. Free access should be provided to the burner fronts, observation ports, and operating valves.
2. All instrumentation and controls should be complete, operational, and checked for proper calibration and action.
3. External indicators permanently marked or installed on damper shafts and registers are necessary for positive determination of position while the boiler is in service.
4. Personnel protection from hot surfaces should be provided by restricting access or by covering the hot surfaces with insulation.
5. Find potential air or flue gas leaks in the furnace of out of service boilers operated with positive furnace pressure by operating the forced draft fan at high flow rates. Leaks that can be felt or heard should be repaired before returning the boiler to service.
6. Safety and relief valve outlets should be piped so they cannot discharge on people or any property that may be damaged. The discharge piping should be supported so that loads (piping weights and dynamic forces during operation) transmitted to the relief valves are minimized. The weight supported by the valve should not exceed the weight of a short elbow and drip pan or comparable weight of a direct connected free hanging discharge pipe. Installations requiring long discharge piping runs should not have those discharge piping runs directly connected to the valve. The valve manufacturer should be consulted if the weight to be loaded on a valve outlet exceeds a short elbow with a drip pan.

9.4 Limit control tests

All limit controls should be tested periodically. Refer to the maintenance schedule as a starting point and discuss the details with your installer. A test gage should be used to check the operation of all pressure controls. In general, the tests are to be performed as follows. Some tests may not apply to your specific installation.

9.4.1 High-Limit Steam Pressure Control.

Disconnect power to boiler controls and place a test lead across the contacts of the operating steam pressure controller. Check setting of high-limit control. It should be higher than operating control, but lower than MAWP & SV/SRV set point. Restore power to controls and fire boiler. Allow boilers to fire until steam pressure reaches setting of high-limit control. Control should operate at this point, shutting off flow of fuel to burner. If test is O.K., disconnect power and remove the test lead. Reset manual high-limit switch, and fire boiler. Observe boiler for proper operation.

9.4.2 High & Low gas pressure switch limit test & adjustment. See Figure 43

The maximum and minimum pressure range of the gas train is on the rating plates on the front of the boiler. If any readings are above this range, or if adjustments can't be consistently made within this range, then other issues like pressure regulators or line pressure need to be addressed first.

For setting and testing the pressure switches:

Close the main manual gas shutoff valve and install a monometer or calibrated gage in test port that will see the same pressure as the switch. Reopen the main manual gas shutoff valve. When finished, close the main manual shutoff valve, remove calibrated gage or monometer, and restore the test plug. Restore the main manual gas valve to full open.

Setting the low pressure switch:

Cycle the burner to high fire and a gas pressure reading. Using the main manual gas shutoff valve, throttle down the gas flow to a point there the reading is approximately 10% below the full open reading. Then adjust the low gas pressure switch until it breaks and shuts down the burner. Restore main manual gas shutoff valve to full open.

Testing the low pressure switch:

Set the burner to high fire and use the main manual gas shutoff valve to throttle the gas flow. The low gas pressure switch should immediately break and shut down the burner at about 10% reduced pressure.

For setting and testing the high pressure switches:

If the high gas pressure switch (HGPS) is located downstream of the metering valve, adjustment and testing of the HGPS is performed at high fire. If the HGPS is located upstream of the metering valve, then adjustment and testing is performed at low fire.

Cycle the burner to firing rate, and take gas pressure reading. Slowly adjust the switch until it breaks and shuts down the burner, then reverse the adjustment so that setting is approximately 10% greater than the reading at which the switch broke.

9.4.3 Electrical Limit Controls.

All electrical current limiting or overload devices, including fuses and thermal overload elements, should be inspected to determine that they are properly sized and in good condition. Switches, starters, and relays should be checked for proper operation.

9.4.4 Oil Pressure Supervisory Switch. (If used on installation with separate pump set.)

Manually turn down burner cock to burner until oil pressure drops below minimum recommended by the burner manufacturer. Burner should shut off. If test is okay, reset firing cock, restart burner, and check operation.

10 TROUBLESHOOTING

If burner does not start, check the controller fault code in the burner manual.

1. Check all electric fuses.
2. Check water level in boiler.
3. Check limit controls to make sure they are making circuit.
4. Push motor or starter reset button.
5. Push reset button on the programming control.
6. Push reset on high and low gas pressure switches.
7. Push reset button(s) on LWCO and temperature devices.
8. If burner then fails to start, call a qualified service technician.

Refer to your burner manual, look for sections about start up, flame sensors, flame safe guard, etc...

To stop burner

1. Switch off burner control switch or push emergency door switch.
2. Do not kill the feedwater pump until boiler is cooled or boiler is full.

Burner adjustments

The burners manual should be used for reference on burner adjustment, however, Look for

1. The flame should not be inside the turn around. if the burner is adjusted so that flame is intruding into the turnaround during normal operation. **NOTICE!** This voids the SBW warranties.
2. The flame should not be impinging on the walls of the furnace.
3. If you are having problems adjusting the flame using the burners controls, draft controls may need to be adjusted, or added if not present.
4. Probe style switches can give a false closed switch signal because of contamination from the boiler out procedure.

Switch problems

1. If the LWCO is always showing low water, you could have a collapsed float ball.
2. Probe style switches (common LWCO) can give a false closed switch signal because of contamination. Clean water side of probe holder.

Leaking

If water starts coming out of the smoke box doors, this is common during initial cold start up. If this does happen during start up, but stops after the boiler has warmed up, this is ok. If this happens during normal operation when the boiler is warm, then you may have a tube leak. This could also just be the result of condensation if the boiler room is humid. If you believe you have a tube leak, call your local boiler service technician. If they do find a tube leak, it is possible that re-rolling the leaking tubes will solve the problem.

Fan rotation

Even when factory tested, the fan motor can be wired backwards in the field. Observe the fan rotation indicator marked on the fan. The diagram below shows how the three phase wiring can control a fan going clockwise (cw) vs. counterclockwise (ccw). In general, incorrect fan rotation is corrected by switching the position of two wires.

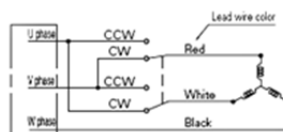

Fan rotation wiring
Figure 44

11 Out of service operations

11.1 Shutdown

When shutting down a boiler, switch the burner to manual, set the burner to low fire for a few moments, then turn the burner off. As the boiler steam flow drops toward zero, it will probably be necessary to close the main feedwater isolation valve and manually regulate drum water level with the bypass valve. Most feedwater flow control valves will not shut off tightly. When the boiler pressure falls below the header pressure and the drum level stabilizes with no feed water flowing, the boiler may be isolated. When the non-return valve, if any, on the steam outlet has closed, close feedwater valves and main steam stop valve. Run down the stem on the non-return valve to hold the disk on its seat. Where two stop valves are used, open the drain between and see that it is clear and bleeds off the pressure in the line. After pressure falls to 25 psig, slowly open the drum vents to prevent formation of a vacuum that might cause subsequent leakage at gasketed joints. In order to prevent baking-on of sludge, it is recommended that blowdown be conducted before the boiler cools.

11.2 Boiler taken out of service

When a boiler is taken out of service, it should be laid-up using either the wet or dry procedure.

NOTICE!

SBW does not warranty boilers out of operation that are not properly laid up for extended periods of time. If the boiler could be subject to freezing temperatures when out of service, the boiler must be laid up dry.

If draining the boiler is not practical, the laid up wet procedure may be used. Wet boiler layups are not recommended for periods longer than 30 days. SBW does not Warranty boilers laid up wet for more than 30 days.

ALWAYS KEEP THE FUEL SUPPLY VALVE(S) SHUT OFF IF THE BURNER IS SHUT DOWN FOR AN EXTENDED PERIOD OF TIME.

11.3 Boiler laid up dry

1. Allow the boiler to cool and shut of the water supply.
2. Drain, clean, and dry the boiler thoroughly (both fire and water sides)
3. Fuel and electricity to the unit shall be shut off. Use proper tag and lock out procedures.
4. An oil coating of fire side metal surfaces is beneficial when the boiler is not used for extended periods of time. This will prevent oxidization of the metal. Care should be taken to avoid putting oil on the firebox thermal blankets.
5. Place desiccant inside the boiler, primary junction box, and burner control panel
6. Close up all opening to the boiler preventing leakage of humid air into the boiler.
7. Fuel oil lines should be taken out of service should be drained and flushed of residual oil and refilled with distillate fuel.
8. When the lay up time if finished, see the re-commissioning section

11.4 Boiler laid up wet procedure

1. Fill the boiler to overflowing with the highest quality water available. Steam condensate, soft water, or filtered fresh water all generally acceptable. Raw city water should not be used.
2. While maintaining boiler water temperature at 120°F minimum to remove oxygen, drain off boiler water from bottom drain until it runs clear.
3. Add enough caustic soda to the hot water to maintain approximately three hundred fifty (350) parts per million of alkalinity and also add enough sodium sulfite to produce a residue of sixty (60) parts per million of this chemical.
4. When all the dissolved gases are released and chemicals mixed into the water (approximately 1 hr.)
5. Completely close up the water side of the boiler so that open air does not come into contact with the water.
6. Dry the flue gas side of the boiler.
7. Fuel and electricity to the unit shall be shut off. Use proper tag and lock out procedures.
8. The fire side should then be cleaned. An oil coating of fire side metal surfaces is beneficial when the boiler is not used for extended periods of time. This will prevent oxidization of the metal. Care should be taken to avoid putting oil on the firebox thermal blankets.
9. Place desiccant on wooden or plastic trays in the fireside of the boiler. Do not fill the trays more than half way. Also place small amount of desiccant in the junction box and burner control panel.
10. Close up all opening to the boiler preventing leakage of humid air into the boiler.
11. Fuel oil lines should be taken out of service should be drained and flushed of residual oil and refilled with distillate fuel.
12. When the layup time if finished, see the re-commissioning section.
13. When the boiler is done with a laid-up wet period of time, make sure blowdown is conducted during start up.

11.5 Re-commissioning

1. When approaching the end of your layup time, review the operator logs for any items that may need to be replaced. Some items can take time to procure.
2. Check that you have gaskets/seals to replace any that have been opened. This likely includes gaskets for: Smoke box doors, cleanout plug, four or five hand holes, manway, gauge glass, sight glass, any float level controls. Your spare parts list will be helpful in determining exactly what is needed. SBW or SBW representative can supply you with spare parts.
3. Remove all desiccants placed within the boiler except boiler lizards placed in the water side of the boiler can be left inside.
4. If the boiler was laid up dry, rinse out the water side of the boiler
5. Remove your tag and lock out's
6. See the startup section of this manual. Boil-out procedures do not need to be repeated unless inspection finds oil buildup inside the water side.



Si vas a capacitar a tu equipo hazlo con especialistas

Para más información contáctenos:
+58 241-832-96.40 (Ext. 210)
+58 414-470.48.20



@vaportec



www.vaportec-corp.com



www.vaportec.com.ve

f in

vaportec-corp

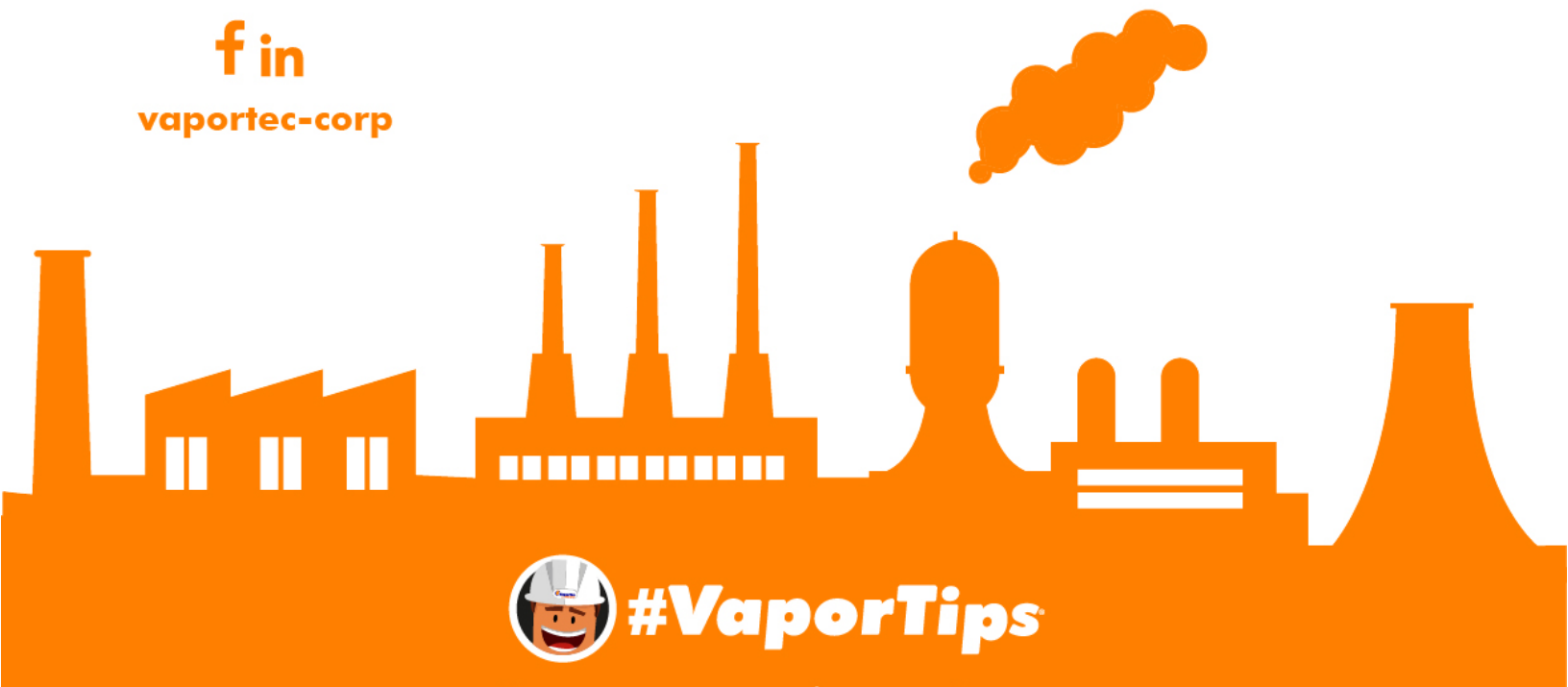

#VaporTips